



# INSTRUCTIONS

-J04979

REV. 2011-05-13

## REAR AGITATOR WHEELS

### GENERAL

#### **⚠ WARNING**

**Install only wheels and installation kits approved for your model motorcycle. Contact a Harley-Davidson dealer to verify fitment. Mismatching wheels and installation kits or installing wheels not approved for your model can cause loss of control, which could result in death or serious injury. (00610c)**

#### **Kit Numbers**

40225-10, 47951-10, 40900112

#### **Models**

For model fitment information, see the P&A Retail Catalog or the Parts and Accessories section of [www.harley-davidson.com](http://www.harley-davidson.com) (English only).

#### **Kit Contents**

See Figure 1 and the Service Parts Tables.

#### **Additional Parts Required**

Separate purchase of tire (44006-09) is required for proper installation of this kit.

This kit includes custom wheel only.

Proper installation of this kit requires the separate purchase of the following parts which are available at a Harley-Davidson dealer:

- Wheel Installation Kit (See Table 3 and Table 4 to determine required installation kit.)
- Brake Disc Screws (See Table 1 to determine proper hardware.)
- Rear Sprocket Screws (See Table 1 to determine proper hardware.) See the P&A Retail Catalog for chrome sprocket hardware.
- Wheel Bearing Remover and Installer (94134-09)

#### **⚠ WARNING**

**The rider's safety depends upon the correct installation of this kit. Use the appropriate service manual procedures. If the procedure is not within your capabilities or you do not have the correct tools, have a Harley-Davidson dealer perform the installation. Improper installation of this kit could result in death or serious injury. (00333a)**

#### *NOTE*

*This instruction sheet references service manual information. A service manual for your model motorcycle is required for this installation and is available from a Harley-Davidson dealer.*

### Recommended Additional Parts

The following Harley-Davidson Genuine Motor Accessories are recommended for proper maintenance and cleaning:

- Harley® Bright™ Chrome Cleaner (94683-99) (Not for use on kit 40900112)
- Harley® Glaze™ Polish and Sealant (99701-84)
- Harley® Wheel and Spoke Brush (43078-99)
- Harley-Davidson® Wheel and Tire Cleaner (94658-98)
- Harley® Preserve Bare Aluminum Protectant (99845-07)

**Table 1. Rear Disc and Sprocket Hardware Fitment**

Hardware	Fitment
<b>Rear Disc Screws</b> (select stock or chrome hardware)	
5 Stock disc screws (43567-92)	All models
Chrome screw kit (46647-05) includes 5 screws	All models
<b>Rear Sprocket Screws</b> (select stock or chrome hardware)	
5 Sprocket screw, stock (3109)	2007 and later Dyna and Softail, 2007 Touring
Chrome screw kit (94773-07) includes 5 screws and washers	2007 and later Dyna and Softail
5 Sprocket screw, stock (3737A)	2000-2005 Dyna, 2000-2006 Softail, 2004-2006 Touring
Chrome screw kit (94773-00A) includes 5 screws and washers	2000-2005 Dyna, 2000-2006 Softail
5 Sprocket screw, stock (3814)	2008 Touring
5 Sprocket screw, stock (3873)	2006 Dyna
5 Sprocket screw, stock (3899)	2000-2003 Touring, 2001 and later Sportster (except Japanese models)
5 Sprocket screw, stock (40439-01)	2002-2006 VRSC and 2007 VRSCR models
5 Sprocket screw, stock (4552)	2007 and later VRSC models (except VRSCR and VRSCSE models)
<b>Rear Sprocket Washers</b>	
5 Sprocket washer, stock (6516HW)	2006 and earlier Dyna, Softail and Touring and 2000 and later Sportster models (except Japanese models)
5 Sprocket washer, stock (7039)	2002 and later VRSC

## INSTALLATION

### NOTES

Use plastic protectors on tire mounting tools and rim clamps when mounting a tire to a painted wheel.

When mounting tires, liberally use tire lube on the wheel and tire.

For tire removal, use plastic inserts between the rim and tire after breaking the bead to create a large enough gap for the rim clamps to get into.

Before removing or installing the wheel, the rear brake caliper must be removed. The cotter pin or spring clip for the axle nut must be replaced. They are available for separate purchase from a Harley-Davidson dealer. See dealer for the correct part number.

1. Remove existing rear wheel assembly. Save axle, axle nut, brake disc and wheel spacers for kit installation. See the service manual.

### NOTE

Install short valve stem (43157-83A) included in the installation kit. Discard all other valve stems.

2. See Figure 1. Install valve stem assembly (H) on wheel. See the service manual.

### NOTICE

**Do not re-use brake disc/rotor screws. Re-using these screws can result in torque loss and damage to brake components. (00319c)**

### NOTICE

**Do not re-use sprocket mounting screws. Re-using sprocket mounting screws can result in torque loss and damage to the sprocket and/or belt assembly. (00480b)**

3. Assemble wheel installation kit components, stock brake disc and sprocket to wheel, using the appropriate service parts table. See the service manual.
4. Install primary bearing with a Wheel Bearing Remover and Installer. See the service manual. The machined groove(s) indicates the primary bearing side.

### NOTES

Install the required (separately purchased) tire.

If the wheel has a yellow dot sticker on the rim, orient the tire so the white dot is opposite of the sticker. If the wheel has a green dot sticker on the rim, orient the tire so the white dot is aligned with the sticker. If no rim dot sticker is present, see the service manual.

5. Mount new tire (purchased separately) to the wheel. See the service manual.
6. Install rear wheel (1), stock axle, sprocket and stock spacers to motorcycle. See the service manual.

## MAINTENANCE AND CLEANING

Chrome parts must be maintained regularly so they keep their original shine and luster.

1. Clean heavily-soiled wheel surfaces using Harley-Davidson Wheel and Tire Cleaner, applied with Harley Wheel and Spoke Brush.
2. Thoroughly clean chrome with a good quality chrome cleaner, such as Harley Bright Chrome Cleaner.
3. After cleaning and polishing, seal the finish with a good quality sealer, such as Harley Glaze Polish and Sealant.

## SERVICE PARTS

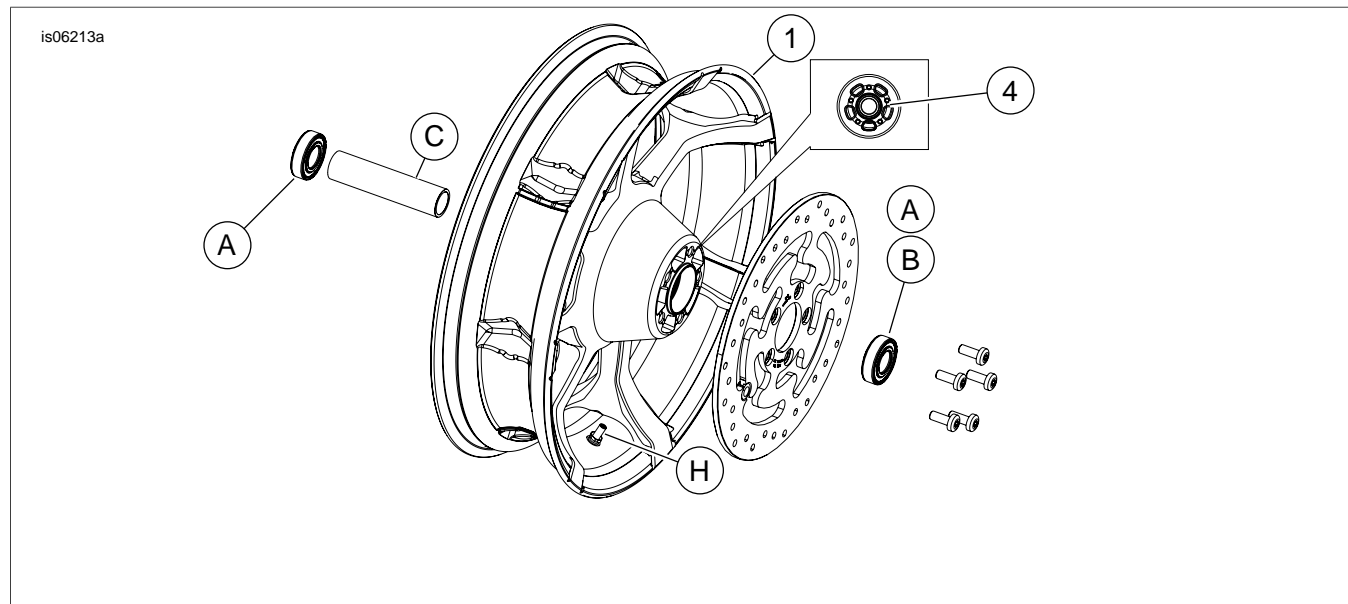

Figure 1. Service Parts: Rear Agitator Wheel (18-inch shown)

Table 2. Service Parts and Wheel Kit Contents

Kit	Item	Description (Quantity)	Part Number
40225-10, 47951-10, 40900112	1	Wheel	Not Sold Separately
Visual indicator mentioned in text:			
	4	Machined groove (all wheels)	

Table 3. REAR 25mm Bearing Wheel Installation Kit (41456-08C)

REAR 25 MM Bearing Wheel Installation Kit (41456-08C)		Item (Quantity Used and Description)								
Fitment	Wheel Size	A	C	D	E	F	H	I	J	
2009 and later FLT without ABS	16 x 5.0 in	2	1	0	0	0	*	*	*	
2009 and later FLT without ABS	18 x 5.0 in	2	1	0	0	0	*	*	0	
2008 VRSCD without ABS	18 x 5.5 in	2	0	0	1	**	*	*	0	
2008 and later FXCW and FXCWC without ABS	18 x 8.0 in	2	0	1	0	0	*	*	0	
2008 and later VRSCAW, VRSCDX and VRSCF without ABS	18 x 8.0 in	2	0	0	1	**	*	*	0	
Installation kits are designed to work with many different wheel styles and fitments. Contact a Harley-Davidson dealer to verify that the wheel and installation kits are both designed and approved for the motorcycle they are being installed on. NOTES: * See NOTE above valve installation step in INSTALLATION to determine which valve stem to use for your particular kit. Discard other valve stem(s). ** See INSTALLATION to determine if shim is required. *** Bearing shim installed under primary bearing.		A	Bearing, regular (2)					9276		
		C	Axle sleeve					41349-07		
		D	Axle sleeve					41358-08		
		E	Axle sleeve					43704-08		
		F	Bearing shim***					41447-08		
		H	Valve stem, short					43157-83A		
		I	Valve stem, long					43206-01		
J	Valve stem, pull thru					40999-87				

**Table 4. REAR 25 MM Bearing ABS Wheel Installation Kit (41453-08C)**

REAR 25 MM Bearing ABS Wheel Installation Kit (41453-08C)		Item (Quantity Used and Description)										
Fitment	Wheel Size	A	B	C	D	E	F	G	H	I	J	
2008 FLT with ABS	16 x 3.0 in	1	1	0	1	0	0	1	*	*	0	
2009 and later FLT with ABS	16 x 5.0 in	1	1	1	0	0	0	0	*	*	*	
2009 and later FLT with ABS	18 x 5.0 in	1	1	1	0	0	0	0	*	*	0	
2008 VRSCDa with ABS	18 x 5.5 in	1	1	0	0	1	**	0	*	*	0	
2008 and later VRSCAWa, VRSCDXa, VRSCXa and VRSCFa with ABS	18 x 8.0 in	1	1	0	0	1	**	0	*	*	0	
Installation kits are designed to work with many different wheel styles and fitments. Contact a Harley-Davidson dealer to verify that the wheel and installation kits are both designed and approved for the motorcycle they are being installed on. NOTES: * See <i>NOTE</i> above valve installation step in INSTALLATION to determine which valve stem to use for your particular kit. Discard other valve stem(s). ** Primary bearing. Bearing must be installed with red side facing the wheel. *** Bearing shim installed under primary bearing.		A	Bearing, regular								9276	
		B	Bearing, ABS**								9252	
		C	Axle sleeve								41349-07	
		D	Axle sleeve								41900-08	
		E	Axle sleeve								43704-08	
		F	Bearing shim***								41447-08	
		G	Bearing shim***								43904-08	
		H	Valve stem, short								43157-83A	
		I	Valve stem, long								43206-01	
		J	Valve stem, pull thru								40999-87	