



# INSTRUCTIONS

-J04804

REV. 2009-01-13

## HYBRID CAM PLATE AND HIGH FLOW OIL PUMP KIT

### GENERAL

#### Kit Number

25284-08

#### Models

For model fitment information, see the P&A retail catalog or the Parts and Accessories section of [www.harley-davidson.com](http://www.harley-davidson.com) (English only).

#### Additional Parts Required

Proper installation of this kit requires the separate purchase of the following additional items:

Table 1. Additional Parts Required

Description	Part Number
Spacer Kit	25285-08
Cam Service Kit	17045-99C
Drive Gear Retention Kit	25533-99A
Splined cam drive sprocket (1999 Dyna and Touring models only)	25716-99
Cam Support Plate Oil Control Kit (1999 Dyna and Touring models only)	94667-00

#### Tools and Supplies Required

Proper installation of this kit also requires the use of the following tools and materials:

- CAMSHAFT/ CAMSHAFT BEARING REMOVER/ INSTALLER (HD-43644)
- For ALL applications: CRANKSHAFT/ CAMSHAFT SPROCKET LOCKING TOOL (HD-42314).

For 2001 - 2005 Dyna, 2001 - 2006 Softail, 2002 - 2006 Touring, and 2001 carbureted Touring models only: CAMSHAFT LOCKING TOOL (HD-47941).

- Loctite® 262 Threadlocker and Sealant - Red (H-D Part Number 99759-99)
- Loctite® 243 Threadlocker and Sealant - Blue (H-D Part Number 99642-97)
- Loctite® 7649 Cleaner/Primer (H-D Part Number 98968-99)

### WARNING

The rider's safety depends upon the correct installation of this kit. Use the appropriate service manual procedures. If the procedure is not within your capabilities or you do not have the correct tools, have a Harley-Davidson dealer perform the installation. Improper installation of this kit could result in death or serious injury. (00333a)

#### NOTE

This instruction sheet refers to service manual information. A service manual for this year/model motorcycle is required for this installation and is available from a Harley-Davidson dealer.

#### Kit Contents

See Figure 8 and Table 2.

### REMOVAL

### WARNING

To prevent accidental vehicle start-up, which could cause death or serious injury, disconnect battery cables (negative (-) cable first) before proceeding. (00307a)

### WARNING

Disconnect negative (-) battery cable first. If positive (+) cable should contact ground with negative (-) cable connected, the resulting sparks can cause a battery explosion, which could result in death or serious injury. (00049a)

1. Refer to the service manual and follow the instructions to remove the seat and disconnect the battery cables, negative (-) cable first. Retain all seat mounting hardware.

### WARNING

Gasoline can drain from the carburetor fuel line when disconnected from fuel valve fitting. Gasoline is extremely flammable and highly explosive, which could result in death or serious injury. Wipe up spilled fuel immediately and dispose of rags in a suitable manner. (00256a)

#### NOTES

Installing this kit requires removal and installation of the cam support plate. Refer to the service manual for instructions with the following exception pertaining to cam compartment components:

The crank and primary cam sprocket flange bolts are specially hardened, and the flat washers are of a special diameter and have ground surfaces. Use **ONLY** the parts provided in the Drive Gear Retention Kit (H-D Part Number 25533-99A, sold separately) when installing this kit.

The crank sprocket flange bolts and primary cam sprocket flange bolts **ARE NOT** interchangeable.

2. Refer to the service manual to remove and discard the crank sprocket flange bolts and primary cam sprocket flange bolts and washers.
3. **For 1999 models only:** Refer to the service manual to remove and discard the currently installed cam drive sprocket.
4. Refer to the service manual to remove and disassemble the cams from the support plate and oil pump. Discard the support plate and oil pump.
5. **For 1999 - 2000 Dyna, 2000 Softail, 1999 - 2000 Touring, and 2001 EFI Touring models only:**

Inspect the cams, chain, sprockets and chain tensioners for wear, and replace as needed. Refer to the service manual for inspection and replacement procedures.

**For 2001 - 2005 Dyna, 2001 - 2006 Softail, 2002 - 2006 Touring, and 2001 carbureted Touring models only:**

Inspect the cams and secondary cam chain for wear, and replace as needed. Refer to the service manual for inspection and replacement procedures. The primary cam chain, primary sprockets and both tensioners will be replaced by **new** components from the kit.

**For ALL models and years:**

Discard the guide, as it will not be used.

## INSTALLATION

1. **ALL models:** See Figure 1. Obtain the new Rear Cam Roller Bearing Kit (H-D Part Number 8983) from inside the Cam Service Kit (H-D Part Number 17045-99C, purchased separately), and install as indicated in Step 2.

### NOTE

See Figure 2. If not enough of the splined shaft is exposed to install the sprocket, omit the spacer (4) and proceed to Step 2e. When the bearing inner race is started onto the machined area, remove the flange bolt (5), flat washer (6) and sprocket, then assemble using the spacer (4). Repeat Step 2e to fully install bearing inner race.

### CAUTION

To center thrust washer, be sure o-ring is installed in relief groove. Damage to bearing cage and engine can occur if thrust washer is not centered. (00473b)

2. See Figure 1. Install the O-ring (5), thrust washer (4) and bearing inner race (3) onto the rear camshaft as follows:
  - a. See Figure 2. To properly locate the thrust washer (2), install the O-ring (3) in the grinding relief groove on the splined end of the rear camshaft between the machined area and the secondary cam sprocket.

Do not stretch or break the O-ring as the O-ring is **not sold separately**, and damage will require purchase of a new Rear Cam Roller Bearing Kit.

- b. Slide the thrust washer down the rear camshaft until centered over the O-ring in the grinding relief groove.
- c. Slide the bearing inner race (1) down the rear camshaft until contact is made with the shoulder of the machined area.
- d. Install the primary cam sprocket spacer (4) and sprocket on the camshaft, and secure using the thicker flat washer (6) and long flange bolt (5) from the Drive Gear Retention Kit (H-D Part Number 25533-99A, purchased separately).
- e. Wrap a clean shop rag around the camshaft to get a firm grip and also to protect your hand from the sharp edges of the sprocket. Tighten the flange bolt until the bearing inner race makes firm contact with the thrust washer (2).
- f. Verify that the thrust washer is locked in place and cannot be rotated. If necessary, install the shaft in a vise using brass jaw inserts, and further tighten the flange bolt until the desired result is achieved.
- g. Remove the flange bolt, flat washer, sprocket and spacer.

### NOTES

See Figure 1. The front and rear cam bearings **are not interchangeable**. The rear bearing is a roller bearing, and the front bearing is a ball bearing.

Bearings may be a press-to-loose fit. If necessary, clean the OD of the bearing and apply Loctite 243 - Blue before installation. Use caution to avoid getting compound on the rollers or bearing ID.

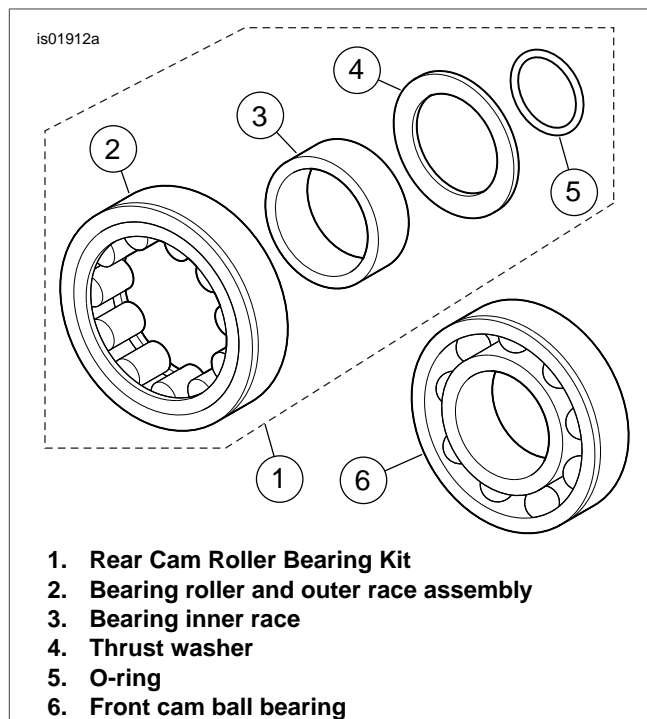
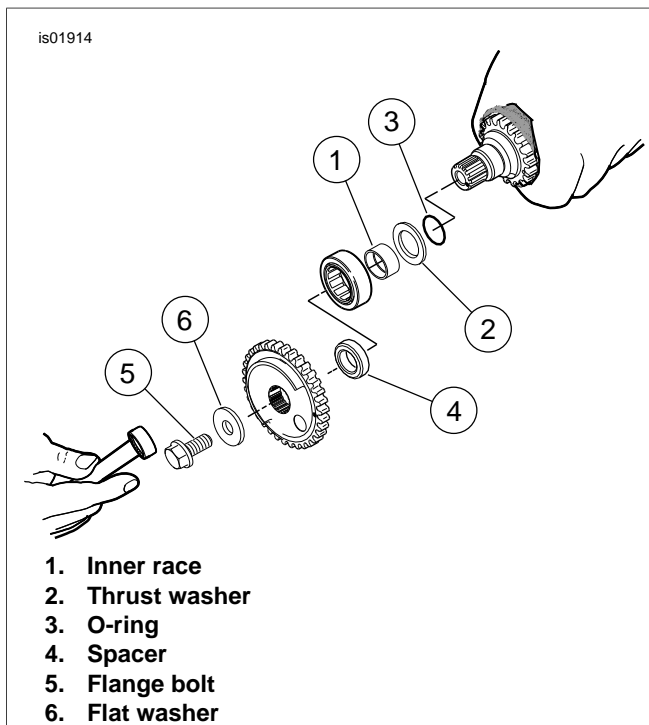

Figure 1. Cam Bearings



**Figure 2. Install Bearing Inner Race with O-ring and Thrust Washer using Cam Drive Sprocket**

3. **For 1999 Touring and Dyna models only:** Install the Cam Support Plate Oil Control Kit (H-D Part Number 94667-00, purchased separately) into the billet cam support plate, after verifying the crankcase version, per instructions included in **THAT** kit.
4. See Figure 1. Install the **new** front cam ball bearing (6) and rear cam roller bearing (1) into the cam support plate as follows:
  - a. See Figure 3. Obtain the CAMSHAFT/CAMSHAFT BEARING REMOVER/INSTALLER (HD-43644).
  - b. With the secondary cam chain side facing up, place the cam support plate on the support block (1) so that the outer races of the bearings are properly supported. Note that one corner of the support block is contoured to accommodate the chain guide blocks cast into the front of the support plate.
  - c. Center the new bearing over the bearing bore with the lettered side up. Slide the pilot shaft of the bearing driver (3) through the bearing into the hole of the support block.
  - d. See Figure 4. Center the bearing driver (1) under the ram of the arbor press. Press on the driver until bearing (2) makes firm contact with the counterbore in the cam support plate (3).
  - e. Repeat the procedure to install the second bearing.
5. Apply Loctite 243 - Blue to the threads of the four bearing retainer plate screws. Fasten the bearing retainer plate to the cam support plate. Tighten the screws in a crosswise pattern to 20-30 **in-lbs** (2.3-3.4 Nm).
 

**For 2004 and earlier models only:** Verify that the hole in the retainer plate is properly aligned with the secondary cam chain oiler.

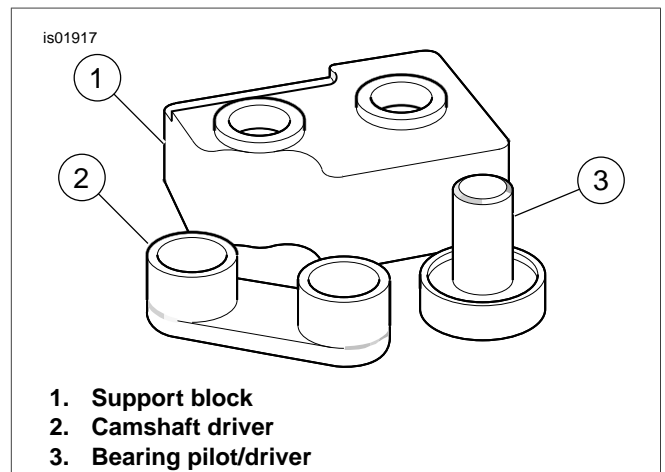

**Figure 3. Camshaft and Camshaft Bearing Remover/Installer**

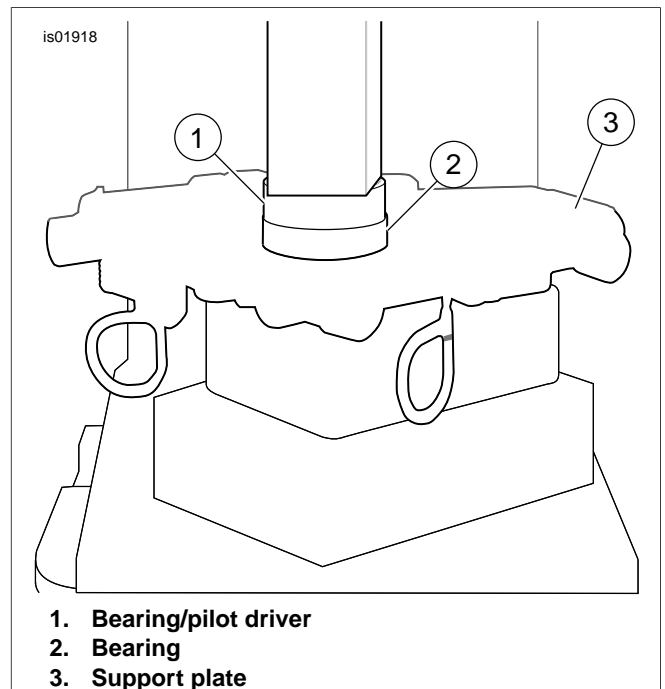

**Figure 4. Press Bearings into Cam Support Plate**

6. Place the cam support plate back on the support block, if removed. The block supports the inner races of the bearings as the camshafts are installed.
7. See Figure 5. Align the punch marks on the teeth of the secondary cam sprockets (outboard faces). Use a colored marker to carefully mark the punch-mark locations on the inboard side of the sprocket teeth. These marks help align the camshafts when they are pressed into the bearings.
8. Place the secondary cam chain around the sprockets of both the front and rear camshafts. To maintain the original direction of rotation, the colored marks on the chain link during disassembly must face opposite the cam support plate during installation.
9. Position the camshafts on opposite ends of the chain, then verify that the colored marks placed on the inboard side of the sprocket teeth are aligned.

**NOTE**

Do not mix camshafts during the press procedure. The rear camshaft, which can be identified by the splined shaft, must press into the roller bearing at the rear of the cam support plate.

10. Maintaining the position of the camshafts on the chain with the colored marks in alignment, place the sprocket ends of the camshafts into the bearings.

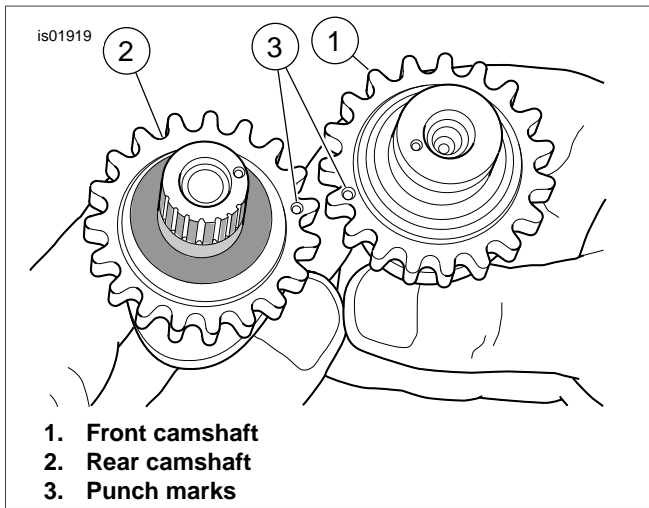

**Figure 5. Align Punch Marks on Teeth of Camshaft Sprockets**

11. Place the cup of the camshaft driver (Figure 3, Item 2) over the end of the **front camshaft only**.

**CAUTION**

**During press procedure, keep tensioner shoe clear of chain to prevent damage to tensioner assembly. (00474b)**

12. Center the end of the front camshaft under the ram, then slowly apply pressure to the driver to just start the front camshaft into the bearing ID.

**CAUTION**

**Be sure rear camshaft is aligned during press procedure. Misalignment can cause inner race to catch on bearing rollers resulting in bearing damage. (00475b)**

13. Slowly apply pressure to the driver on the front camshaft, while wiggling the rear camshaft as necessary to guide the inner race between the bearing rollers.
14. When the inner race on the rear cam is started into the roller bearing, apply pressure to the driver until the front camshaft is fully seated. If necessary, keep finger pressure at the top of the rear camshaft to make sure that the assembly remains square and the inner race moves to the installed position in the roller bearing.
15. Refer to the service manual and check for proper cam-to-cam timing using a straightedge along the punch marks.
16. Install the new retaining ring in the groove at the end of the front camshaft.
17. See Figure 6. Be sure the primary and secondary cam chain tensioners are assembled as shown. If assembled incorrectly, the tensioners will not function properly. Install the secondary cam chain tensioner. Tighten the fasteners

to 90-120 **in-lbs** (10.2-13.6 Nm). Remove the locking clip from the tensioner.

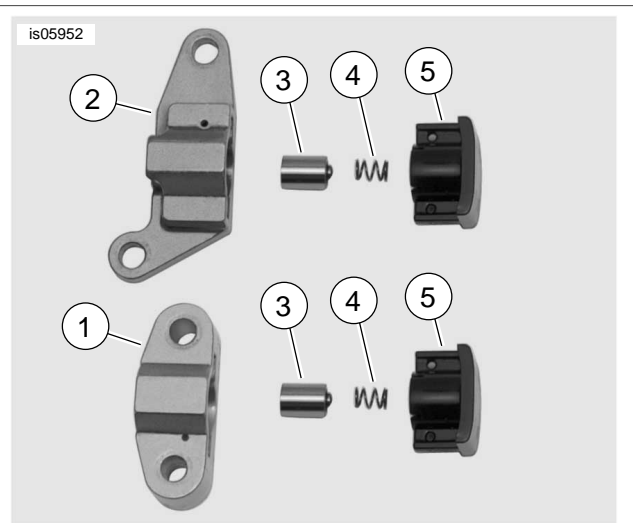

**Figure 6. Primary and Secondary Cam Chain Tensioners**

**Figure 6. Primary and Secondary Cam Chain Tensioners**

**NOTE**

Replace the original cam plate to crankcase O-ring with the **new O-ring (H-D Part Number 11301) from the Cam Service Kit (H-D Part Number 17045-99C, purchased separately).**

18. Refer to the service manual and install the cam plate with the **new** oil pump from the kit in place of the original oil pump.
19. Apply a thin film of clean engine oil to the splines of the rear cam.
20. Install the splined sprocket onto the rear camshaft.

**For 1999 - 2000 Dyna, 2000 Softail, 1999 - 2000 Touring, and 2001 EFI Touring models only:**

These vehicles will retain the **original style** primary cam chain and sprockets, to work with the camshaft position sensor. The roller style chain and sprockets **in THIS kit** are to be discarded.

Refer to the service manual and install the original splined sprocket (H-D Part Number 25716-99) and spacer onto the rear camshaft.

**For 2001 - 2005 Dyna, 2001 - 2006 Softail, 2002 - 2006 Touring, and 2001 carbureted Touring models only:**

These vehicles will use the **roller style** chain and sprockets included **in THIS kit**. A thicker spacer will be required with the new roller style camshaft sprocket. The Spacer Kit (H-D Part Number 25285-08, purchased separately) contains spacers of proper thickness.

Select a new spacer 0.020 inch (0.508 mm) thicker than the original for initial chain alignment evaluation, using the thickness chart information in the instructions included with the Spacer Kit.

**NOTES**

Refer to the service manual and verify alignment at the crank and primary cam sprocket punch marks.

Verify alignment at the crank and primary cam sprocket faces. Use spacers provided in the Spacer Kit (H-D Part Number 25285-08) to maintain alignment at  $\pm 0.10$  inch (2.54 mm).

21. Install the correct style primary cam chain, as noted in Step 20. See Figure 7.

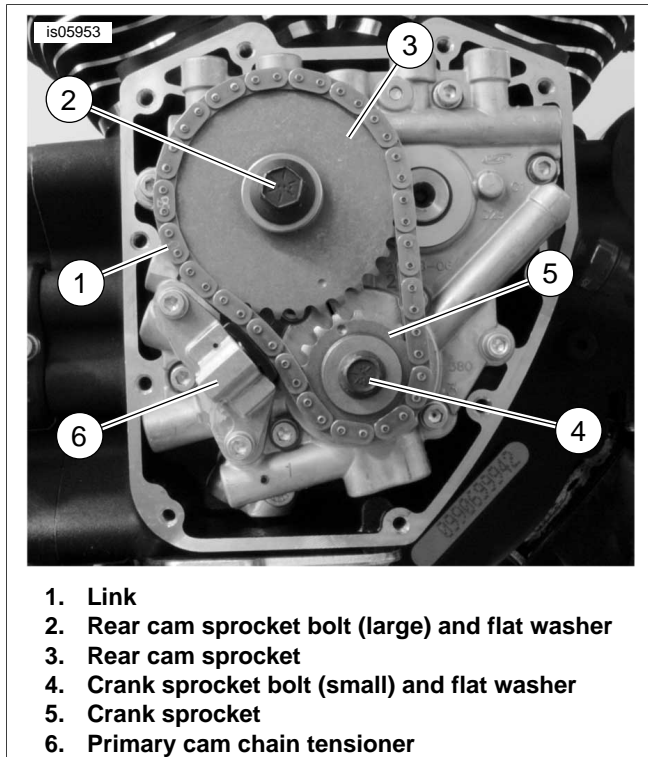

Figure 7. Cam Support Plate Assembly

22. Install the primary hydraulic tensioner (6). Tighten the fasteners to 90-120 **in-lbs** (10.2-13.6 Nm). Remove the locking clip from the tensioner.

23. Use the **new** cam drive sprocket flange bolt and washer (2), and the **new** crank flange bolt and flat washer (4) provided in the Drive Gear Retention Kit (H-D Part Number 25533-99A), purchased separately.

**WARNING**

Apply threadlocker to maintain clamp load on flange bolt. A loose flange bolt can cause engine failure, which could result in death or serious injury. (00476c)

24. Install the new flange bolts and washers as follows:
- a. Make sure the bolt and washer threads are clean and free from oil, then apply Loctite Cleaner/Primer 7649 to the threads.
  - b. Apply Loctite 262 - Red to the threads of the flange bolts.
  - c. Apply a thin film of clean engine oil to both sides of the flat washers.
  - d. Start the smaller flange bolt with flat washer to secure the crank sprocket to the end of the crankshaft.
  - e. Start the larger flange bolt with flat washer to secure the primary cam sprocket to the end of the camshaft.
  - f. Obtain the correct locking tool for the application:  
 CRANKSHAFT/CAMSHAFT SPROCKET LOCKING TOOL (HD-42314) for 1999 - 2000 Dyna, 2000 Softail, 1999 - 2000 Touring, and 2001 EFI Touring models.  
 CAMSHAFT LOCKING TOOL (HD-47941) for 2001 - 2005 Dyna, 2001 - 2006 Softail, 2002 - 2006 Touring, and 2001 carbureted Touring models.  
 Position the tool between the crank and primary cam sprockets to prevent rotation. The handle of the tool is stamped "CRANK" and "CAM" to make sure of proper orientation.
  - g. Tighten the crank and primary cam sprocket flange bolts to 15 ft-lbs (20.3 Nm).
  - h. Loosen each flange bolt one full turn.
  - i. Tighten the crank flange bolt to 24 ft-lbs (32.5 Nm) final torque value.
  - j. Tighten the primary cam sprocket flange bolt to 34 ft-lbs (46.0 Nm) final torque value.
  - k. Remove the sprocket locking tool.

**NOTE**

Replace the original cam cover gasket with the **new** cam cover gasket from the Cam Service Kit (H-D Part Number 17045-99C, sold separately).

25. Refer to the service manual and install the cam cover.

# SERVICE PARTS

is05954

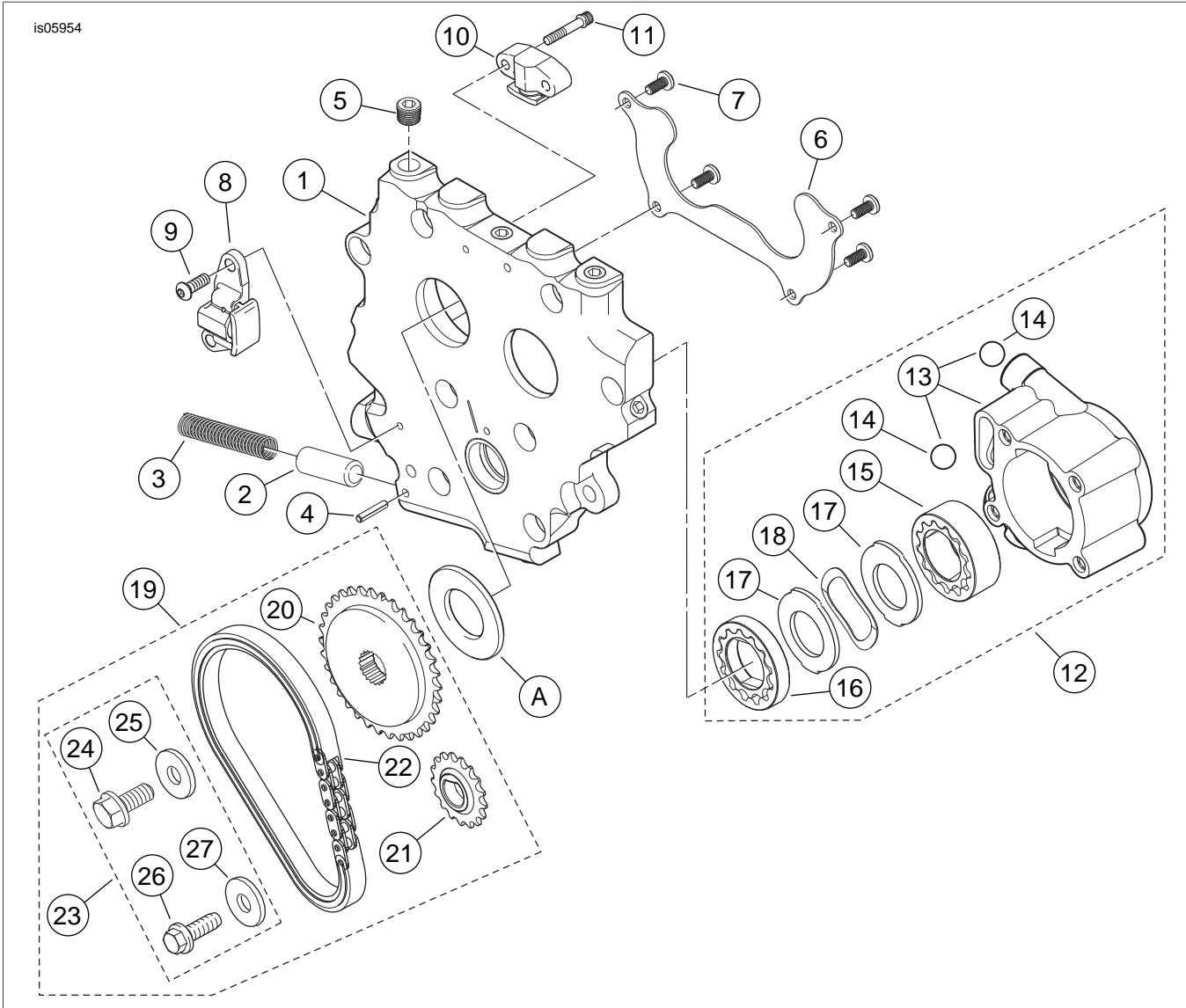

Figure 8. Service Parts, Hybrid Cam Plate and High Flow Oil Pump Kit

## SERVICE PARTS

**Table 2. Service Parts Table**

<b>Item</b>	<b>Description (Quantity)</b>	<b>Part Number</b>
1	Cam plate assembly, hybrid (includes items 2 through 5)	Not sold separately
2	• Relief valve, oil pump (bypass valve)	26400-82 B
3	• Spring, relief valve	26210-99
4	• Roll pin	601
5	• Pipe plug, 1/8 inch NPT	Not sold separately
6	Bearing retaining plate	Not sold separately
7	Screw, self-tapping (4)	68042-99
8	Chain tensioner, primary cam drive chain	39968-06
9	Screw, button head TORX (2)	940
10	Chain tensioner, secondary cam drive chain	39969-06
11	Screw, hex socket (2)	4740A
12	Oil pump assembly (includes items 13 through 18)	26037-06
13	• Housing assembly, oil pump (includes item 14)	Not sold separately
14	• Ball (2)	8873
15	• Gerotor assembly, scavenge	26278-06
16	• Gerotor assembly, pressure	26281-06
17	• Separator plate, gerotor (2)	26282-06
18	• Spring, separator	40323-00
19	Primary drive kit (includes items 20 through 27)	25585-06
20	• Sprocket, cam drive (34 Tooth)	25728-06
21	• Sprocket, cam drive (17 Tooth)	25673-06
22	• Chain, primary cam drive	25675-06
23	• Gear retention kit, cam drive (includes items 24 through 27)	25566-06
24	• Screw, hex flange head (3/8-24 thread)	Not sold separately
25	• Washer, thick	6294
26	• Screw, hex flange head (5/16-18 thread)	Not sold separately
27	• Washer, heat treated	Not sold separately
<b>Items mentioned in text, but not included in kit:</b>		
A	Spacer, cam drive sprocket alignment (from spacer kit, purchased separately)	