



# INSTRUCTIONS

-J04267

REV. 2006-10-02

## ENGINE/TRANSMISSION INTERFACE COVER

### GENERAL

#### Kit Number

66545-07

#### Models

For model fitment information, please see the P&A Retail Catalog or the Parts and Accessories section of [www.harley-davidson.com](http://www.harley-davidson.com) (English only).

#### Additional Parts Required

Loctite® 243 (Blue) Threadlocker and Sealant (H-D Part Number 99642-97) is required for the proper installation of this kit.

#### Kit Contents

See Figure 2 and Table 1.

### INSTALLATION

#### WARNING

**Perform this installation when the engine is cool. Working on or near the exhaust system when the engine is hot could result in severe burns. (00311a)**

1. Refer to the Owner's Manual and follow the instructions given to remove the maxi-fuse.

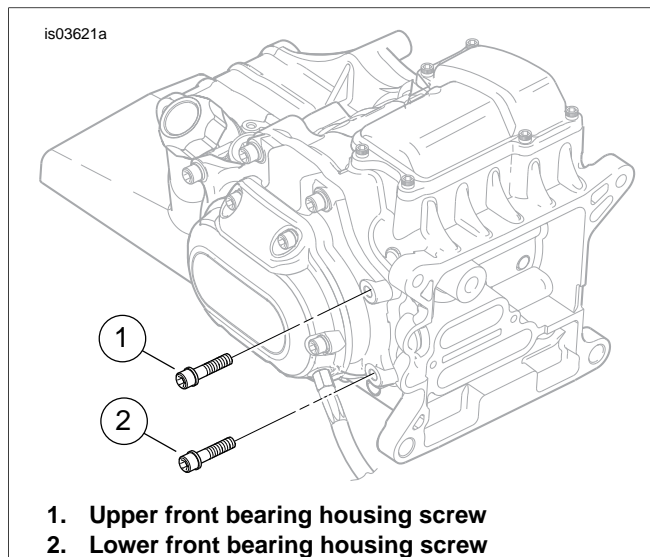

Figure 1. Interface Cover Installation

2. See Figure 1. **Remove** the **upper front** bearing housing screw (1) from the side of the transmission case. **Loosen** the **lower front** bearing housing screw (2).
3. See Figure 2. Obtain the interface mounting bracket (2) from the kit.
4. Hook the slot in the bracket under the head of the loosened lower screw. Install the interface mounting bracket to the bearing housing with the screw removed in Step 2, and tighten **only the lower screw** to 13-18 ft-lbs (17.6-24.4 Nm).
5. Remove and discard the **upper** bearing housing screw installed in Step 4.
6. Obtain the interface cover (1), two screws (3 and 5) and two flat washers (4) from the kit. Place one washer onto the threads of each screw.

#### NOTE

*It may be necessary to loosen and reposition the interface mounting bracket in order to properly align the interface cover.*

7. Position the interface cover to the vehicle.  
Apply a few drops of Loctite 243 (Blue) to the threads of both screws.  
Insert the long screw through the top hole, and the short screw through the bottom hole, and **loosely** fasten the interface cover to the mounting bracket.
8. Align the cover for best appearance. Tighten the screws to 13-18 ft-lbs (17.6-24.4 Nm).
9. Refer to the Owner's Manual and follow the instructions given to install the maxi-fuse.

## SERVICE PARTS

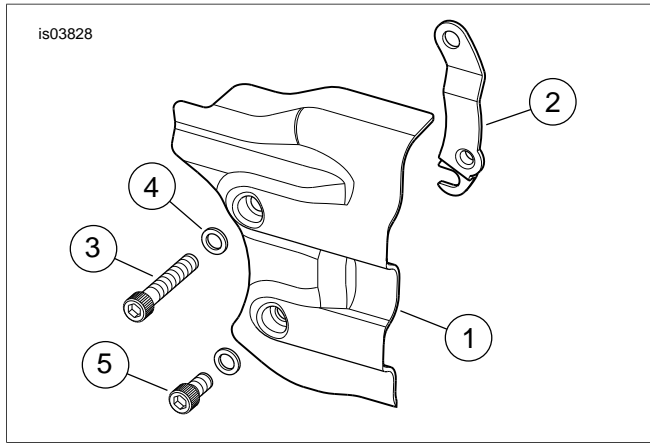

Figure 2. Service Parts, Interface Cover

Table 1. Service Parts

Item	Description (Quantity)	Part Number
1	Cover, interface	Not sold separately
2	Bracket, interface cover	Not sold separately
3	Cap screw, socket head, 5/16-18 x 1.75 in	94337-91T
4	Washer, flat (2)	Not sold separately
5	Cap screw, socket head, 5/16-18 x 0.62 in	94331-91T