



INSTRUCTIONS

-J03985

REV. 2009-05-08

DYNA PASSENGER PILLION SEAT KIT

GENERAL

Kit Number

51404-10, 54089-10

Models

For model fitment information, see the P&A Retail Catalog or the Parts and Accessories section of www.harley-davidson.com (English only).

Additional Parts Required

⚠ WARNING

Do not install these seat kits on motorcycles that are not equipped with an appropriate grab strap and passenger footpegs. If footpegs and grab strap are not installed, passenger could fall from moving motorcycle or grab onto operator, causing loss of control and death or serious injury. (000410b)

These kits require the separate purchase of a Passenger Footpeg Mounting Kit (50210-06) and passenger footpegs (purchased separately) if installed on a vehicle originally equipped with a solo seat.

⚠ WARNING

The rider's safety depends upon the correct installation of this kit. Use the appropriate service manual procedures. If the procedure is not within your capabilities or you do not have the correct tools, have a Harley-Davidson dealer perform the installation. Improper installation of this kit could result in death or serious injury. (00333a)

NOTE

This instruction sheet references service manual information. A service manual for your model motorcycle is required for this installation and is available from a Harley-Davidson Dealer.

Kit Contents

See Figure 3, Table 1.

REMOVAL

Cover painted surfaces with protective material to avoid damage.

- For Vehicles Equipped with Solo Seat:** Remove rear seat mounting screw from seat.
- For Vehicles Equipped with Solo Seat and Separate Pillion:**
 - Remove rear seat mounting screw from pillion.
 - Remove pillion, grab strap and grab strap mounting hardware.

3. For Vehicles Equipped with Two-Up Seat:

- Remove rear seat mounting screw from seat. Carefully slide seat away from the tank and out of the grab strap.
- Remove grab strap and mounting hardware.

INSTALLATION

- See Figure 1. A retention nut and washer must be installed in the rearmost fender hole (3) and the middle fender hole (4). If these are not installed, follow Steps a and b:
 - See Figure 2. A cable strap may be used as an installation aid to install the retention nut and washer. Place the retention nut (1) over the cable strap (3) so the wide end of the nut rests on the eye of the cable strap. Thread the cable strap up under the fender and through the appropriate fender hole. Pull up on the cable strap to hold the nut snug against the underside of the fender.
 - With the rib on the retention nut seated into the notch in the appropriate fender hole (see Figure 1), slide the retention washer (2) into place from the rear. This will lock the retention nut in place. Remove the cable strap.

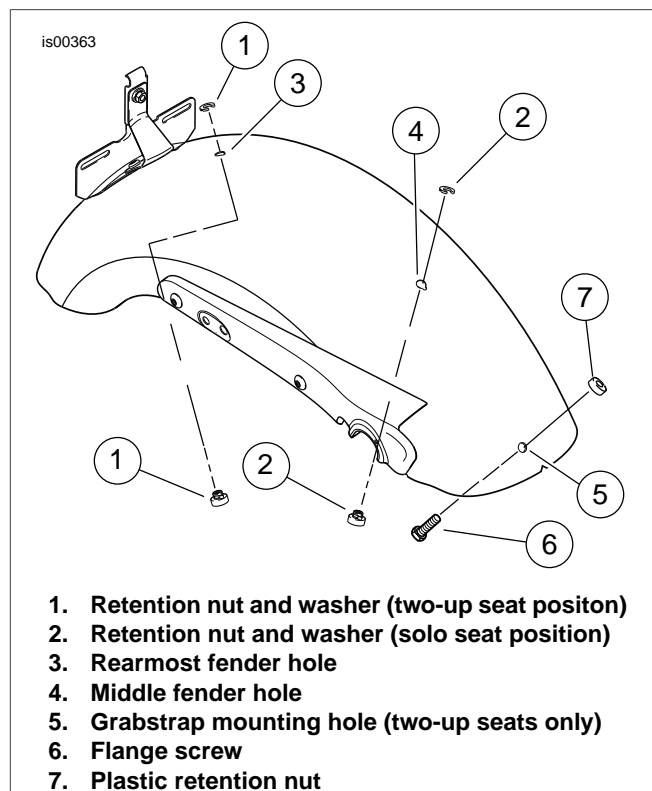

Figure 1. Retention Nut Location

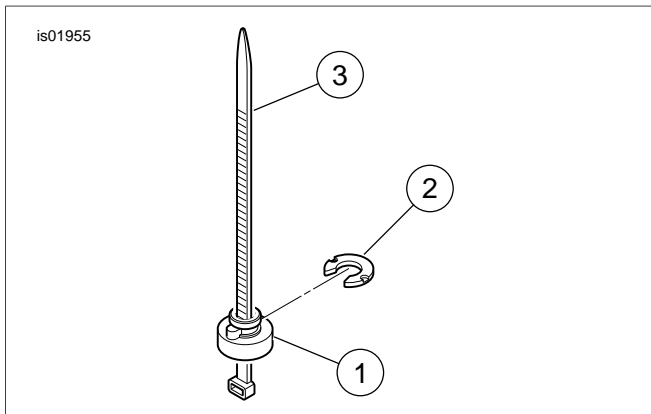

Figure 2. Installation Tool

2. **For Kit 54089-10 Only:** See Figure 3. Clean the rear fender thoroughly and set the pillion into place on the rear fender. Remove the adhesive backing from each bumper (12), position the bumpers under the decorative rivets on the pillion and install bumpers on the fender. Press each bumper firmly into place.
3. Install top hat washer (11) between shoulder bolt and solo seat mounting bracket.
4. Install solo seat (if removed).
5. **For All Models:** See Figure 3. Install the shoulder bolt (6) through the grab strap (5) and into the grab strap mounting hole in the fender.
6. Tighten shoulder bolt to 8-13 ft-lb (11-18 Nm).
7. **For Kit 51404-10:** Slide pillion (1) through grab strap then and engage the shoulder bolt in the slot in the bottom of the pillion. Slide pillion forward until the pillion is fully engaged on the shoulder bolt.
8. **For Kit 54089-10:** Slide grab strap between the lower skirt and the top of the pillion. Engage the shoulder bolt in the slot in the bottom of the pillion. Slide pillion forward until it is fully engaged on the shoulder bolt.
9. Install mounting screw (A) through seat bracket (2 or 4). Tighten securely.

CARE AND MAINTENANCE

For Kit 54089-10: The leather material of the pillion has been pre-conditioned with a leather dressing. To maintain the appearance of the leather, apply Harley-Davidson Leather Dressing (98261-91V), available from a Harley-Davidson dealer.

SERVICE PARTS

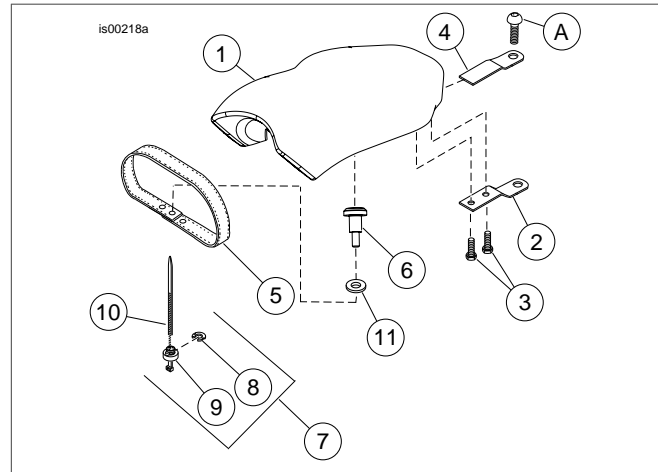

Figure 3. Service Parts: Kit 51404-10 Shown

Table 1. Service Parts Table

Item	Description (Quantity)	Part Number
1	Passenger pillion seat	Not sold separately
2	Seat bracket (Kit 51404-10 only)	51652-97A
3	Cap screw (2) (Kit 51404-10 only)	3588
4	Seat bracket (Kit 54089-10 only)	54105-10
5	Passenger grab strap (Kit 51404-10 only)	51184-00
	Passenger grab strap (Kit 54089-10 only)	54086-10
6	Shoulder bolt (Kit 51404-10 only)	7321
	Shoulder bolt (Kit 54089-10 only)	8253
7	Hardware Kit (includes items 8-9)	59768-97
8	Washer, retention	Not Sold Separately
9	Nut, retention	Not Sold Separately
10	Cable strap	Not Sold Separately
11	Washer, top hat	11895
12	Bumper, pillion (4) (not shown) (Kit 54089-10 only)	11672
Items referenced in text, but not included in kit:		
A	Stock screw	