



INSTRUCTIONS

-J03656

REV. 2005-03-09

TIMER COVER KITS

GENERAL

Kit Number

32972-04A, 32668-98A, 32581-90TB, 32571-98A, 32924-04A, 32675-04A, 32923-04A, and 32584-88TA

Models

Kit number 32584-88TA fits all 1970 and later model motorcycles (except Twin-Cam equipped models).

Kit numbers 32668-98A, 32581-90TB, and 32571-98A fit XL models with horizontal mounting holes on timer cover.

Kit numbers 32972-04A, 32924-04A, 32675-04A, and 32923-04A fit 2004 and later XL model motorcycles.

Kit Contents

See Figure 1 and Table 1, and Figure 2 and Table 2.

INSTALLATION

WARNING

Disconnect negative (-) battery cable first. If positive (+) cable should contact ground with negative (-) cable connected, the resulting sparks can cause a battery explosion, which could result in death or serious injury. (00049a)

NOTE

For kits 32972-04A, 32924-04A, 32675-04A, and 32923-04A, refer to step 1 and 2 for installation instructions.

WARNING

To prevent accidental vehicle start-up, which could cause death or serious injury, remove maxi-fuse before proceeding. (00251a)

1. See Figure 2. Remove and discard the original screws and timer cover.
2. Place new timer cover (1) in position and secure with chrome screws (2).

NOTE

For kits 32584-88TA, 32668-98A, and 32571-98A, refer to steps 3 through 8.

3. Use a 3/8 in. drill bit and drill the heads off the original timer cover rivets. Remove original timer cover.

NOTE

If the inner timer cover has been riveted in place and access to the cam position sensor is required, use a left hand drill and carefully remove the rivet heads. If a right hand drill is used, the sensor plate screw heads could break off when trying to remove the rivet.

NOTE

To make the cam position sensor tamper proof, follow steps 4 through 6. If the cam position sensor is not required to be tamper proof, skip steps 4 through 6.

4. Remove and discard inner cover retaining screws. Leave gasket (if used) and inner cover in position.
5. See Figure 1. Place washers (4) over rivets (3) and place rivets into inner cover holes so the backs of the rivets go into the sensor plate screws' tapped holes.
6. Use a standard rivet tool and install rivets, securing inner cover to sensor plate screws.
7. Use the self-tapping screw (5) to cut threads into the remaining inner cover holes. Discard screw after use.
8. Place new timer cover (1) in position over inner cover (A) and secure with chrome screws (2).

NOTE

For kit 32581-90TB, refer to steps 9 and 10.

9. Use 3/8 in. drill bit and drill the heads off the timer cover rivets. Remove original timer cover.
10. Place new timer cover in position and secure with chrome screws (Part Number 9462) from kit.

WARNING

Connect positive (+) battery cable first. If positive (+) cable should contact ground with negative (-) cable connected, the resulting sparks can cause a battery explosion, which could result in death or serious injury. (00068a)

11. Connect positive (+) battery cable first.

SPECIAL CARE INSTRUCTIONS

NOTE

To prevent damage to the chrome surface, do not use any detergents, chemical solvents, polishes or abrasive cleaning agents.

These Chrome Sportster Timer Cover kits are chrome plated, with paint filled accents.

To keep this surface in best condition, lightly wipe with a Harley-Davidson Micro Fiber cloth, part number 94663-02, using clear water or a mild Harley-Davidson cleaner such as:

- Sunwash (part number 94659-98),
- Bug Remover (part number 94657-98) or
- Harley Gloss (part number 94627-98).

NOTE

These cleaners are available separately or as part of the Harley Care Starter Kit, part number 94671-99 from your Harley

Davidson Dealer.

SERVICE PARTS

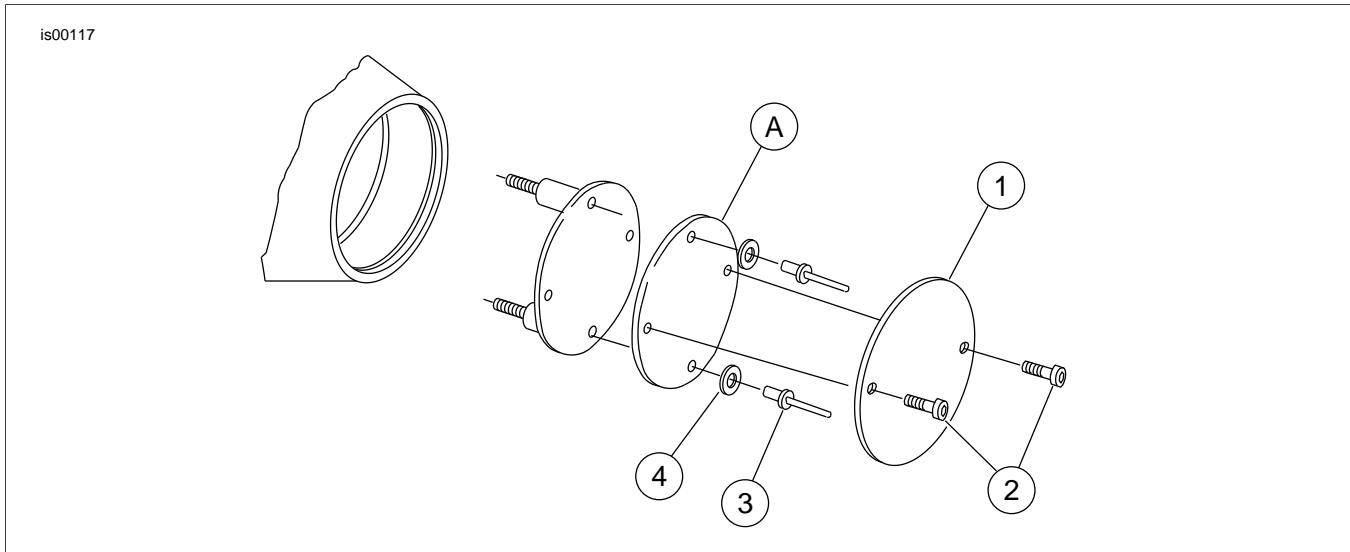

Figure 1. Service Parts: Timer Cover Kits 32584-88TA, 32668-98A, and 32571-98A

Table 1. Service Parts: Timer Cover Kits 32584-88TA, 32668-98A, and 32571-98A

Item	Description (Quantity)	Part Number
1	Timer cover	Not Sold Separately
2	Screw, button head, 10-32 x 0.25 in., S.S. chrome (2)	9463
3	Rivet (2)	8501
4	Rivet washer (2)	6335
5	Self-tapping screw (not shown)	3659
Items mentioned in text, but not included in kit:		
A	Inner cover	

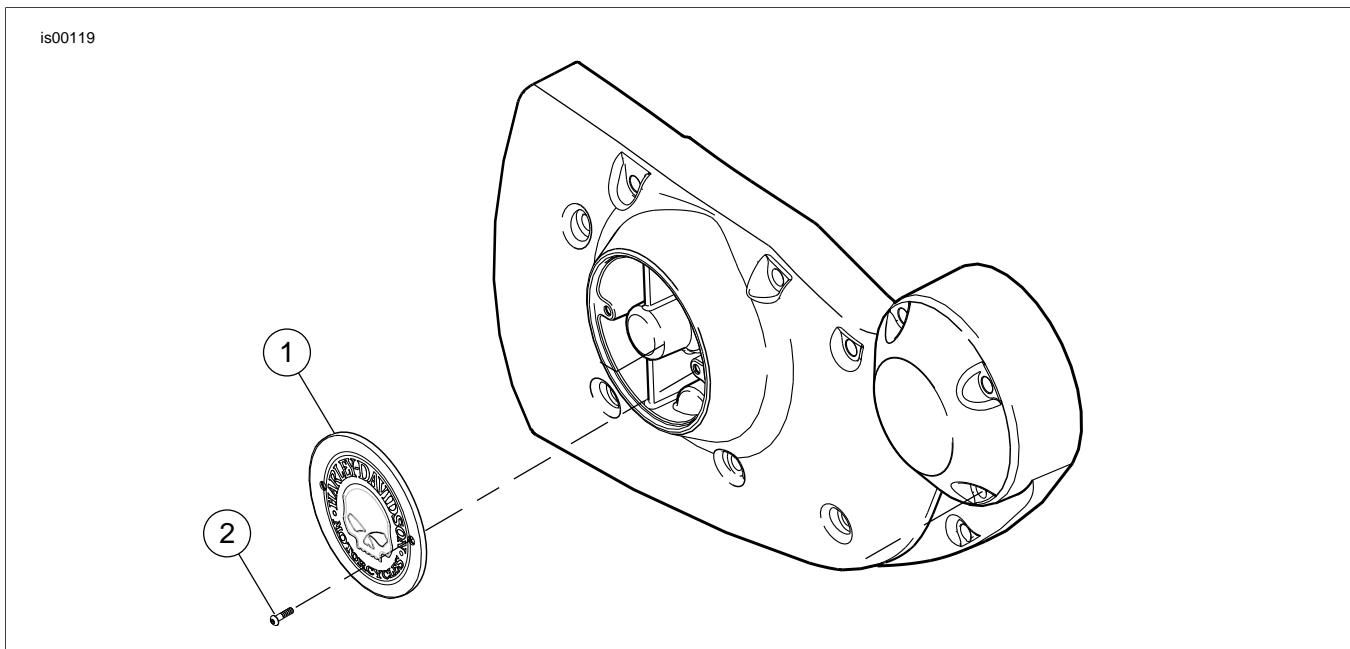

Figure 2. Service Parts: Timer Cover Kits 32972-04A, 32924-04A, 32675-04A, and 32923-04A

Table 2. Service Parts: Timer Cover Kits 32972-04A, 32924-04A, 32675-04A, and 32923-04A

Item	Description (Quantity)	Part Number
1	Timer cover	Not Sold Separately
2	Screw, Torx® S.S. chrome (2)	9462