



# INSTRUCTIONS

-J03227

REV. 2006-07-05

## SKULL FOOTPEG KIT

### GENERAL

#### Kit Number

50370-04

#### Models

This kit fits all Harley-Davidson motorcycles equipped with "male mount" style footpeg supports.

#### Kit Contents

Table 1. Kit Contents

Description (Quantity)	Part Number
Assembly, footpeg (left)	50407-04
Assembly, footpeg (right)	50408-04

### INSTALLATION

#### NOTE

A Service Manual for your motorcycle is available at any Harley-Davidson Dealer.

1. See Figure 1. Remove the locknuts and screws (some models may have a pin (1) and retaining ring (2) installed) that hold the existing footpegs in place. Save all hardware for installation of the new footpegs.
2. Remove the existing footpegs along with the spring washers (3). Save the spring washers for later installation.

#### NOTE

When performing Step 3, make sure the spring washer (3) is positioned inside of the footpeg support with the square edge towards the inside of the support as shown in Figure 2.

3. See Figure 2. Install the new footpegs in the same manner as the old footpegs were installed. Place a spring washer (1), along with the mount end of the footpeg, inside the slots of the footpeg supports.
4. Secure each footpeg and spring washer with the screw and locknut removed earlier. Tighten the locknuts to 18-22 ft-lbs (24.4-30.0 Nm).
5. Refer to Figure 1. For each footpeg, loosen the adjusting screw (4) in the recessed hole until the footpeg rotates. Position the footpeg as desired, then tighten the adjusting screw to 21 ft-lbs (29 Nm).

### WARNING

Position footpegs so rider can operate foot controls without interference. Failure to have full access to foot controls can cause loss of control, which could result in death or serious injury. (00313a)

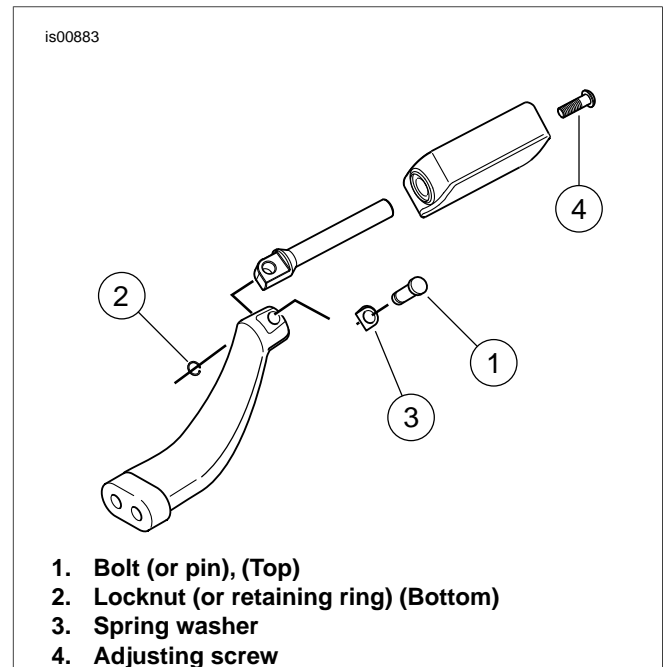

Figure 1. Footpeg Removal/Installation

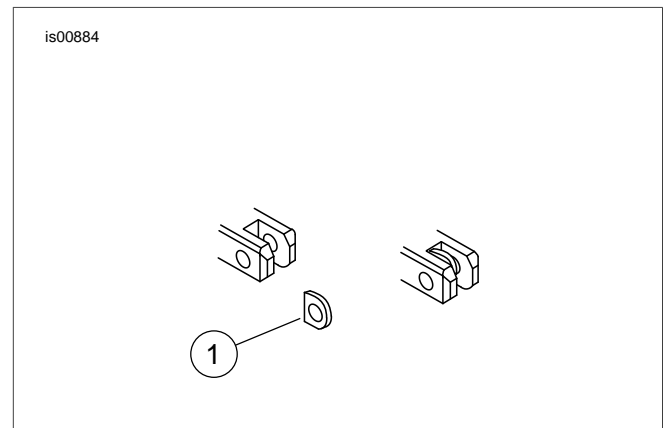

Figure 2. Footpeg Spring Washer Installation