



INSTRUCTIONS

-J02866

REV. 2007-08-06

CRUISE CONTROL KIT FOR FLHR/I AND FLHRS/I MODELS

GENERAL

Kit Number

77197-04, 77198-04

Models

For model fitment information, please see the P&A Retail Catalog or the Parts and Accessories section of www.harley-davidson.com (English only).

Additional Parts Required

⚠ WARNING

The rider's safety depends upon the correct installation of this kit. Use the appropriate service manual procedures. If the procedure is not within your capabilities or you do not have the correct tools, have a Harley-Davidson dealer perform the installation. Improper installation of this kit could result in death or serious injury. (00333a)

NOTE

This instruction sheet references Service Manual information. A Service Manual for your model motorcycle is required for this installation and is available from a Harley-Davidson Dealer.

Kit Contents

See Figure 10 and Table 1.

INSTALLATION

1. Remove seat, left saddlebag, left side cover and air cleaner assembly following instructions in applicable Service Manual.
2. Review the CRUISE CONTROL-ULTRA MODELS section in the applicable Service Manual before attempting to install this kit.

Install Cruise Control Module

⚠ WARNING

To prevent accidental vehicle start-up, which could cause death or serious injury, disconnect negative (-) battery cable before proceeding. (00048a)

⚠ WARNING

Disconnect negative (-) battery cable first. If positive (+) cable should contact ground with negative (-) cable connected, the resulting sparks can cause a battery explosion, which could result in death or serious injury. (00049a)

1. Refer to the appropriate Service Manual and remove battery.

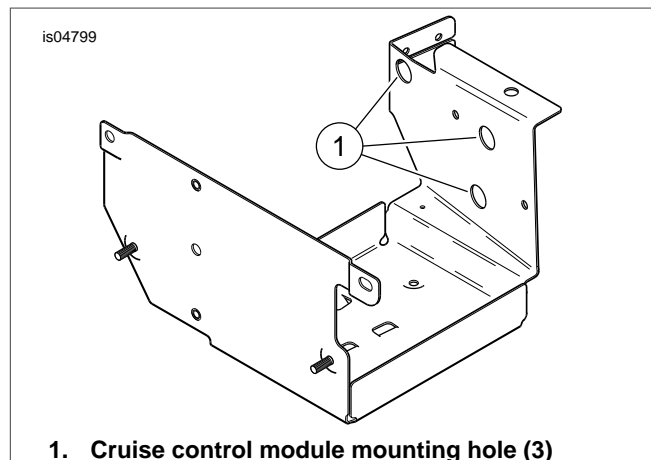

1. Cruise control module mounting hole (3)

Figure 1. Battery Box (Right Side View)

2. See Figure 1. In battery box, identify the location of the three mounting holes (1) (on left side of panel) for mounting the cruise control module.
3. See Figure 10. Obtain the cruise control module (1) with cruise cable attached and three grommets (5) from kit. Install the grommets on studs of cruise control module with small diameters outward.
4. See Figure 2. While holding cruise control assembly in place near its mounting location, feed the cruise control cable through the hole in frame crossmember plate and route under rear spark plug wire staying on inner side of fuel line components. Carefully curve cable toward the right and continue routing up under the fuel tank and over the top of the engine stabilizer bracket, then down between cylinder heads. Leave in place temporarily.
5. See Figure 10 and obtain a harness retainer (4) from kit and secure the cruise cable to crossmember plate with barb as shown. On California models, remove the EVAP hose from cable clip and secure hose with one of the cable strap (8).

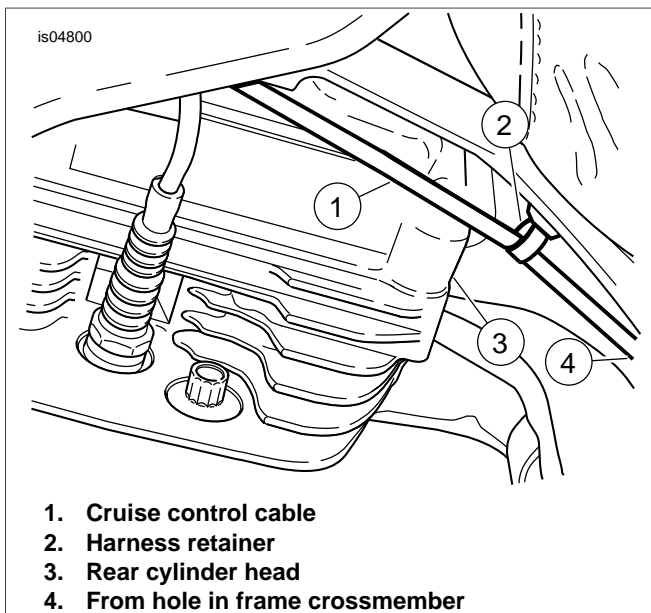

Figure 2. Cruise Control Cable Routing (Left Side View)

NOTE

Prior to performing the next step, it may be necessary to cut the wire ties securing the main harness to the frame tube (above mounting area) and temporarily move harness aside to allow adequate room for cruise assembly installation. It may also be necessary to move the charcoal canister hose, if equipped, to the side and secure to frame tube with cable strap (8).

6. See Figure 3. Remove the fuse block cover panel by pulling straight out from mounts and temporarily position the cover away from the mounting area. Align the cruise control assembly (1) studs and grommets with mounting holes in battery box and push module firmly into position. Make sure grommets enter mounting holes in battery box.

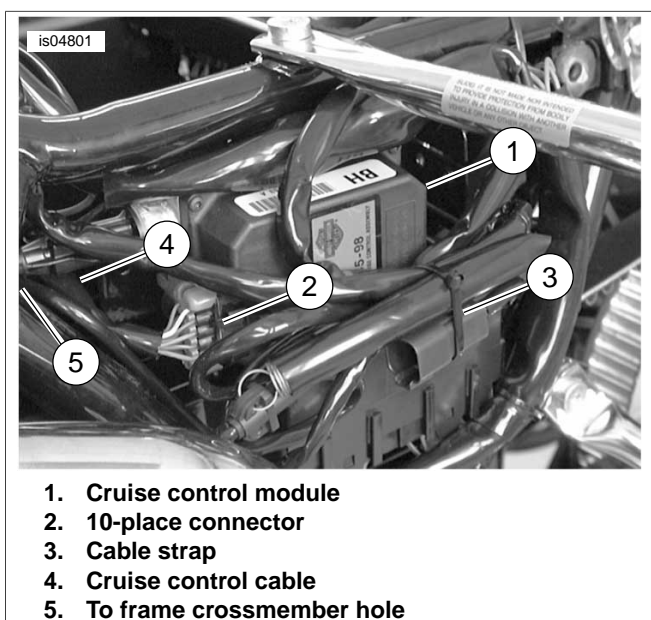

Figure 3. Mount Cruise Control Module

7. See Figure 10. Obtain the three flange locknuts (7) and install to cruise control module studs (inside battery box). Tighten nuts to 9-11 ft-lbs (12.2-15 Nm). Locate the 10-

place connector harness (normally fastened to frame tube next to battery box) and cut the cable strap. Route downward and install the 10-place connector into cruise module.

8. Reinstall the fuse block cover panel by sliding (side channels) back onto mounts. Obtain cable straps (Item 8, Figure 10) from kit. Bundle wire harnesses (moved to install cruise module) along side of cruise module to allow the side cover to be reinstalled.

NOTE

See Figure 10. Use new retaining ring (6) from kit when installing cable end to carburetor/induction module.

9. Follow instructions in applicable Service Manual to connect cruise cable to carburetor or induction module.

Install New Right Handlebar Control with Harness

CAUTION

Do not remove or install the master cylinder assembly without first positioning a 5/32-inch (4 mm) thick insert between the brake lever and lever bracket. Removing or installing the master cylinder assembly without the insert in place may result in damage to the rubber boot and plunger on the front stoplight switch. (00324a)

NOTE

Use the eyelet of an ordinary cable strap if the cardboard insert is not available.

1. See Figure 4. Place a 5/32 inch cardboard insert between the brake lever and lever bracket.
2. Using a T-27 TORX® drive head, remove two screws with flat washers securing the handlebar clamp to the master cylinder housing. Remove brake lever/master cylinder assembly and clamp from the handlebar. Use a cable tie or other means to keep the assembly out of the way.

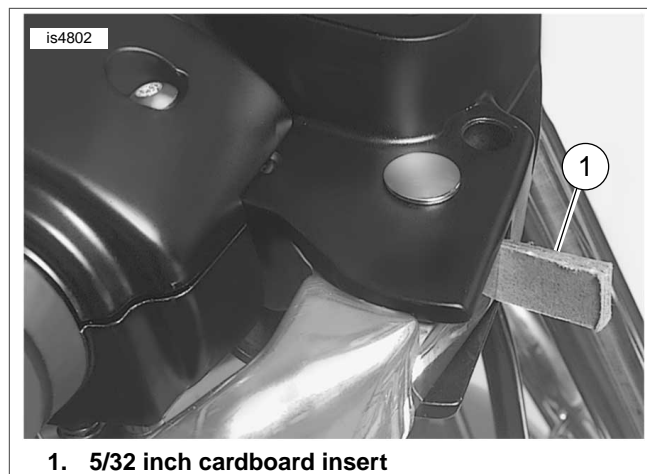

Figure 4. Install Cardboard Insert

3. Using T-25 TORX drive head, remove the upper and lower switch housing screws.

NOTE

The friction shoe is a loose fit and may fall out or become dislodged if the lower switch housing is turned upside down or shaken.

4. Remove the friction shoe from the end of the tension adjuster screw. Save friction shoe for reinstallation.
5. See Figure 5. Remove the brass ferrules from the notches on the inboard side of the throttle control grip, then remove ferrules from the cable end fittings. Save ferrules for reinstallation.

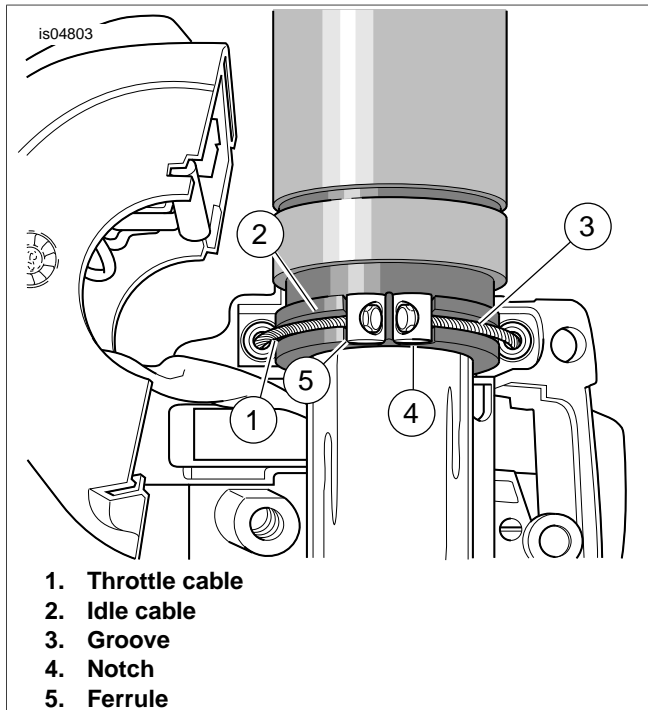
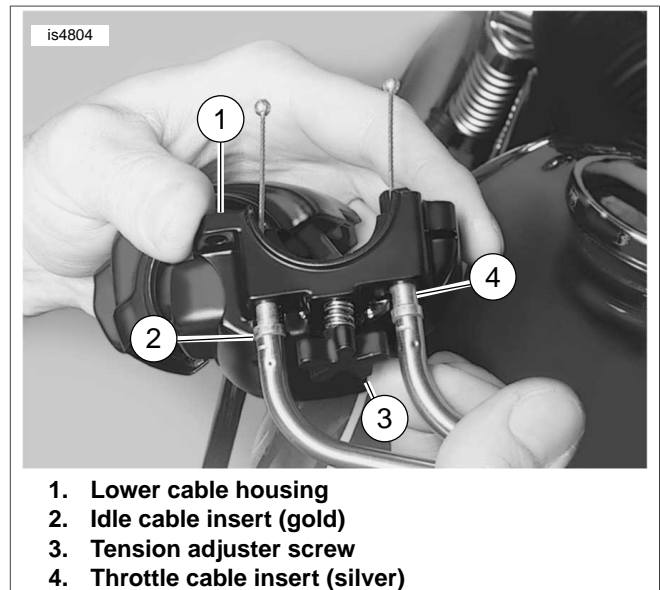

Figure 5. Remove Throttle and Idle Control Cables

NOTE

It is not necessary to remove the throttle control grip.

6. See Figure 6. Pull the crimped inserts at the end of the throttle and idle control cable housings from the lower switch housing. For best results, use a rocking motion while pulling. Place a drop of light-weight oil on the retaining rings, if necessary. Save inserts for re-installation.
7. Remove the cables from the switch housing, then separate the upper and lower switch halves.
8. Follow the instructions in applicable Service Manual and remove windshield and nacelle.



1. Lower cable housing
2. Idle cable insert (gold)
3. Tension adjuster screw
4. Throttle cable insert (silver)

Figure 6. Upper Right Handlebar Switch Housing

NOTE

In the next step, the right side Deutsch connectors are black; the left side Deutsch connectors are gray.

9. Trace the right handlebar wiring harness to the 6-place Deutsch connector and disconnect connector halves. Note the existing harness routing and cable ties securing harness to handlebars. Remove and discard the right hand control and harness assembly.
10. See Figure 10. Obtain the new right handlebar control and harness assembly (2) from kit. Install the new harness 6-place connector in same place as connector removed in the previous step. Locate the unused 4-place connector half (next to the 6-place) and install the 4-place connector from the new harness to the 4-place connector in head-lamp assembly.
11. At new handlebar control assembly, hold the lower switch housing with concave side facing upward. Install the tension adjuster screw and spring with the friction shoe (saved from Step 4) so that pin hole is over the point of the tension adjuster screw. Adjust the tension adjuster two or three turns to hold assembly in place.

NOTE

The friction shoe is a loose fit and may fall out or become dislodged if the switch housing is turned upside down or shaken.

12. See Figure 6. Push the throttle and idle control cables into the lower switch housing until they snap into place. Perform the following:
 - a. Obtain the crimped inserts removed in Step 6. Note the different diameter inserts crimped into the end of the throttle and idle control cable housings.
 - b. Push the larger diameter insert (silver) on the throttle cable housing into the larger hole in front of the tension adjuster screw.
 - c. Push the smaller diameter insert (gold) on the idle cable housing into the smaller hole at the rear of the tension adjuster screw.

NOTE

To aid assembly, place a drop of light-weight oil on the retaining rings of the crimped inserts. Always replace the retaining rings if damaged or distorted.

- Slide the throttle control grip towards motorcycle until it bottoms against the closed end of the handlebar. Rotate the grip so that the ferrule notches are at the top. To prevent binding, pull the grip back about 1/8 inch (3.2 mm).
- See Figure 5. Position the new lower switch housing beneath the throttle control grip. Install the brass ferrules onto the cables so that the end fittings seat in the ferrule recess. Seat the ferrules in their respective notches on the throttle control grip. Verify that the cables are captured in the grooves molded into the grip.
- Position the upper switch housing over the handlebar and lower switch housing.
- Verify that wire harness conduit is routed in the depression at the bottom of the handlebar. Be sure that the upper switch housing harness will not be pinched under the handlebar when the switch housing screws are tightened.
- Start the upper and lower switch housing screws, but do not tighten.
- See Figure 7. Position the brake lever/master cylinder assembly inboard of the switch housing assembly engaging the tab on the lower switch housing in the groove at the top of the brake lever bracket.
- Align the holes in the handlebar clamp with those in the master cylinder housing and start the two screws (with flat washers). Position the assembly for rider comfort. Beginning with the top screw, tighten the screws to 60-80 **in-lbs** (6-9 Nm) using a T-27 TORX drive head.

NOTE

When performing the following Step, tighten the lower switch housing screw first so that any gap between the upper and lower housings is at the front of the switch.

- Using a T-25 TORX drive head, tighten the lower then upper switch housing screws to 35-45 **in-lbs** (4-5 Nm).

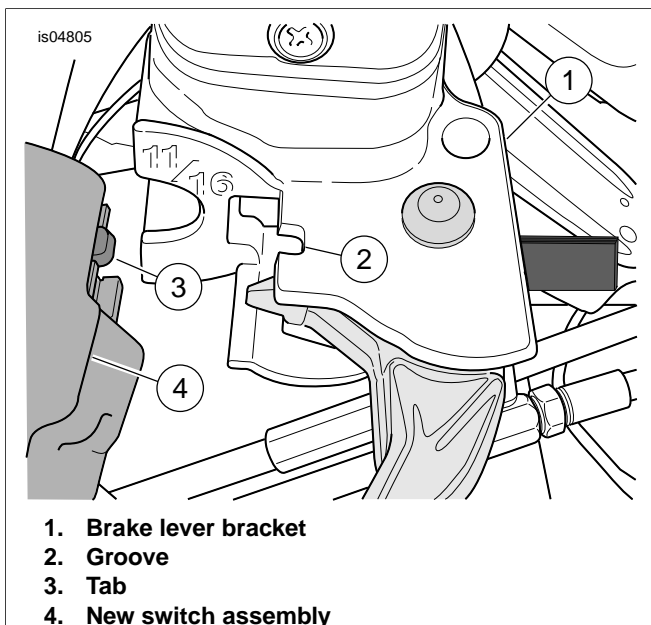

Figure 7. Brake Lever/Master Cylinder and Switch Housing

- Remove the cardboard insert between the brake lever and lever bracket.
- See Figure 10. Obtain two harness retainers (4) from kit. Adjust the harness so it is routed under the handlebar and secure harness conduit to holes in lower side of handlebar by inserting barbed ends of retainers.

Install New Left Handlebar Control with Harness

NOTE

Prior to performing the next step, cut all cable ties securing left control switch harness to handlebars and discard.

- Trace the left control switch harness wiring to the headlamp area (with nacelle removed) and locate the gray 6-place Deutsch connector. Disconnect the handlebar switch half from the connector.
- Using a T-27 TORX drive head, remove the two screws with flat washers securing the handlebar clamp to the clutch lever bracket. Remove the clutch hand lever assembly and clamp from the handlebar. Save all hardware for reinstallation.
- Using a T-25 TORX drive head, remove the upper and lower switch housing screws. Save switch housing screws for reinstallation. Remove the left handlebar control and harness and discard.
- See Figure 10. Obtain the new left handlebar control with harness (3) from kit.

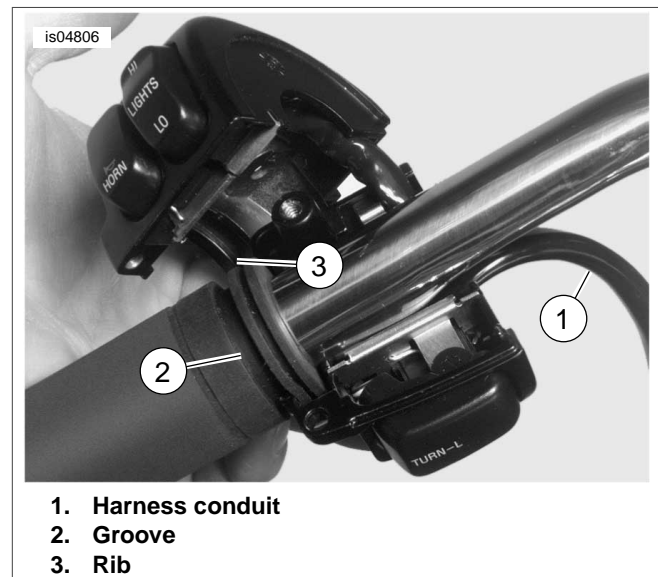

Figure 8. Install Left Handlebar Switch Housing

- See Figure 8. Position the left switch control upper and lower housings onto the handlebar. Be sure that rib on outboard side of switch housings fits in groove molded into the grip.
- Verify that the wire harness conduit is routed in the groove at the bottom of the handlebar. Be sure that the upper switch housing harness will not be pinched under the handlebar when the switch housing screws are tightened.
- Start the upper and lower switch housing screws saved in Step 3, but do not completely tighten at this time.
- See Figure 9. Position the clutch hand lever assembly inboard of the switch housing assembly engaging the tab

on the lower switch housing in the groove at the bottom of the clutch lever bracket. Be sure that harness will not be pinched when installing handlebar clamp. Harness should reside in recess between handlebar clamp and clutch lever bracket.

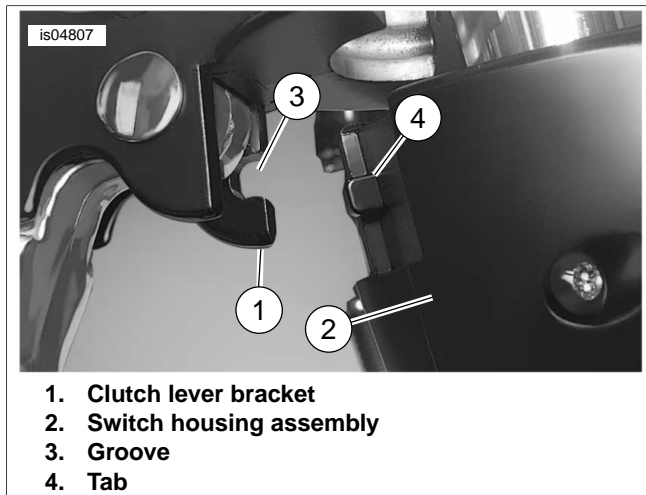

Figure 9. Clutch Lever Bracket and Switch Housing

9. Align the holes in the handlebar clamp with those in the clutch lever bracket and start the two screws with flat washers saved from Step 2. Position the assembly for rider comfort. Beginning with the top screw, tighten the screws to 60-80 **in-lbs** (6-9 Nm) using a T-27 TORX drive head.

NOTE

Always tighten the lower switch housing screw first so that any gap between the upper and lower housings is at the front of the switch.

10. Using a T-25 TORX drive head, tighten the lower and upper switch housing screws to 35-45 **in-lbs** (4-5 Nm).
11. Route left hand control harness under handlebar and down to headlamp area (with nacelle removed). Locate the 6-

place Deutsch connector and connect the 6-place control harness connector.

12. Locate the unused 4-place Deutsch connector and connect the 4-place control harness connector.
13. See Figure 10. Obtain two wire harness retainers (4) from kit and secure harness to handlebar in two places by installing barbs on retainers into holes in handlebar.
14. Follow instructions in applicable Service Manual and install fairing nacelle and windshield.
15. Follow instructions in Service Manual and install left saddlebag, left side cover and air cleaner assembly.

WARNING

Connect positive (+) battery cable first. If positive (+) cable should contact ground with negative (-) cable connected, the resulting sparks can cause a battery explosion, which could result in death or serious injury. (00068a)

16. Refer to the appropriate Service Manual and install the battery.

WARNING

After installing seat, pull upward on seat to be sure it is locked in position. While riding, a loose seat can shift causing loss of control, which could result in death or serious injury. (00070b)

17. Install seat.

CRUISE CABLE ADJUSTMENT AND FINAL TEST

1. Perform cruise cable adjustment. See CABLE LASH INITIALIZATION in applicable Service Manual.
2. Refer to CRUISE CONTROL section in Owner's Manual for cruise control operating instructions.
3. Test ride motorcycle and verify cruise control is operating properly.

SERVICE PARTS

is04808

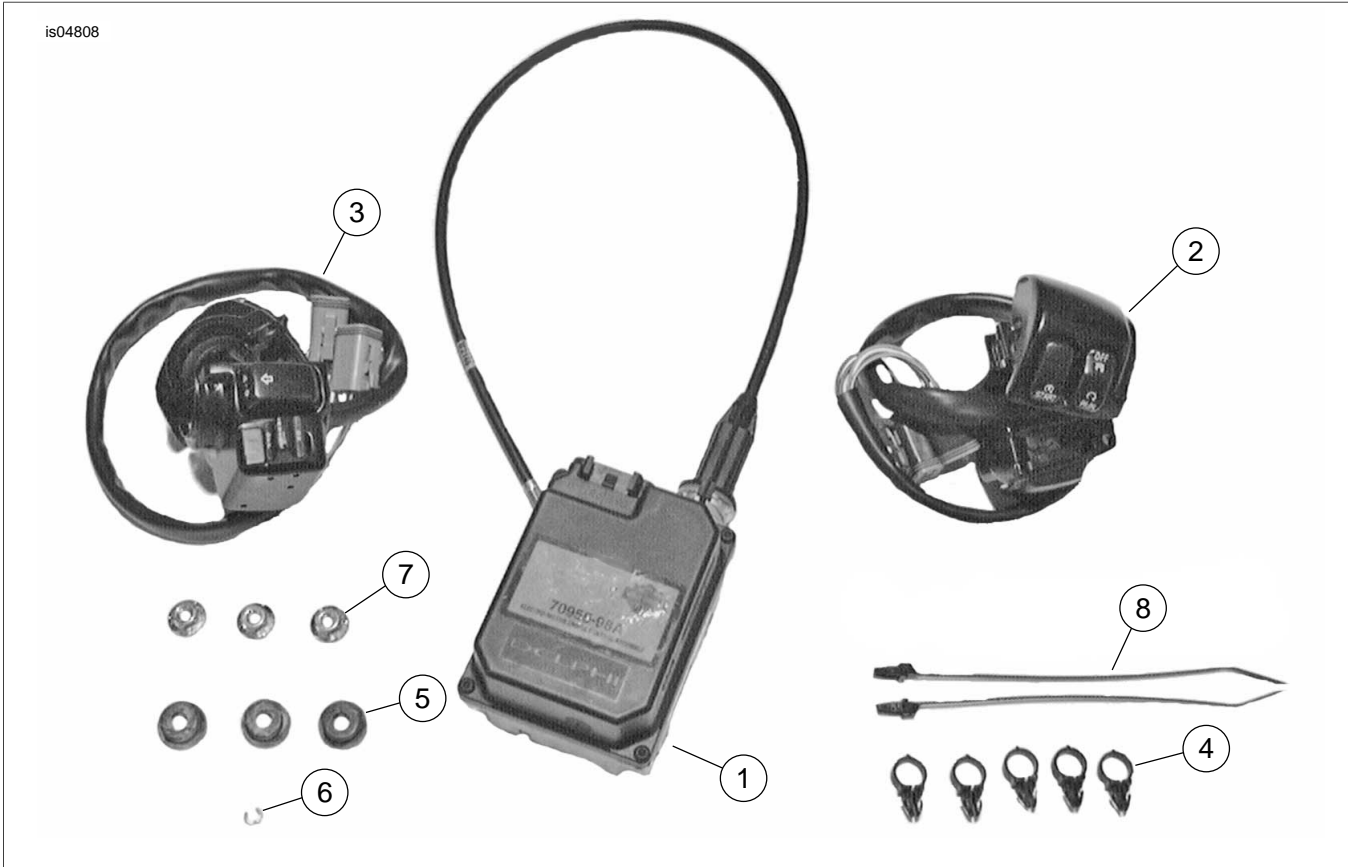

Figure 10. Service Parts for FLHR and FLHRS Cruise Control Kits

Table 1. Service Parts Table

Item	Description (Quantity)	Part Number
1	Assembly, cruise control with harness	70955-04
2	Assembly, hand control, right	Not Sold Separately
3	Assembly, hand control, left	Not Sold Separately
4	Retainer, wire harness (5)	70345-84
5	Grommet (3)	11497
6	Ring, retaining	11193
7	Nut, flange locking (3)	7499
8	Cable strap (2)	10065