



INSTRUCTIONS

-J02839

REV. 2006-02-02

360 DEGREE HIGHWAY FOOTPEG MOUNTING KITS

GENERAL

Kit Number

50929-03, 50832-07

Models

These kits are designed for installation on Harley-Davidson models equipped with 1-1/4 inch front engine guards.

Additional Parts Required

NOTE

This kit requires installing a set of male-mount style footpegs, sold separately and available from your Harley-Davidson dealer.

NOTE

A Service Manual for your model motorcycle is available from a Harley-Davidson Dealer.

Kit Contents

See Figure 2 and Table 1.

INSTALLATION

⚠ WARNING

Position footpegs so rider can operate foot controls without interference. Failure to have full access to foot controls can cause loss of control, which could result in death or serious injury. (00313a)

⚠ WARNING

Mount the footpegs so they will not strike the ground during cornering. Footpegs striking the ground during cornering can cause loss of control, resulting in death or serious injury. (00458b)

NOTE

See Figure 2 for steps 2 through 6.

1. Determine what height on the engine guard you prefer for the final mounting of the footpeg mounts. Mark location, if desired.
2. See Figure 2. Obtain clamp assembly (1) from kit. Wrap the clamp halves around the engine guard and install with hinge pin head facing upward. Place the flatwasher between the ears of the clamp halves. Hold parts in position.
3. Obtain the lockwasher (13), screw (7) and one of the footpeg extensions (14) (long or short depending on kit number) from kit.

4. Position the clamp adapter (10) over the clamp assembly (1) with the "cogged" face of the adapter facing the extension arm (14). Hold clamp adapter in place.
5. Install screw (7) with internal tooth lockwasher (13) through the clamps, the clamp adapter (10) and into the extension arm (14). Position extension arm as desired. Do not tighten completely at this time.
6. Obtain the clevis/extension assembly (6) from kit. Position assembly such that footpeg pivots upward and toward the rear of the bike. NOTE: It may be necessary to loosen the screw slightly and rotate the extension to obtain this position. Tighten item 9 securely.

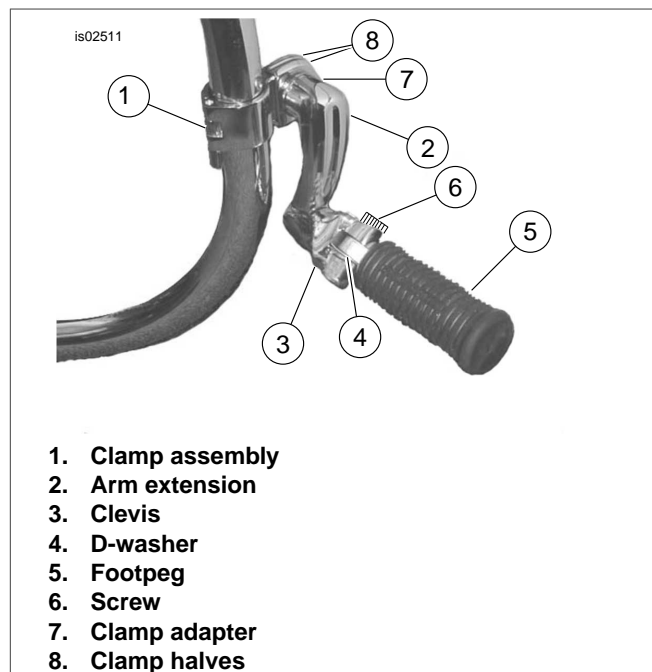

Figure 1. 360 Degree Footpeg Mounting Installed (Shown with Footpeg Installed)

NOTE

The footpeg will be a tight fit if the D-spring washer is installed correctly.

7. Refer to Figure 1. Obtain the footpeg (5), sold separately, D-spring washer (4) and screw (6) from kit. Install the D-spring washer so it is positioned inside the clevis (3) with the square "D" edge towards the inside of the mount. Hold the washer in place and slide the footpeg into position. Install the screw (6) and tighten to 19 ft-lbs (26 Nm).
8. Repeat Steps 1 through 7 for the opposite side. Position the footpeg assemblies so they are at equal heights and symmetrical. Securely tighten each assembly until it cannot be rotated on the guard with reasonable foot pressure, but do not exceed 55 ft-lbs (81 Nm) on item 7.

WARNING

SERVICE PARTS

If footpeg mounting location increases motorcycle width, maintain clearance between motorcycle and surrounding persons or objects. Failure to maintain clearance could result in death or serious injury. (00314a)

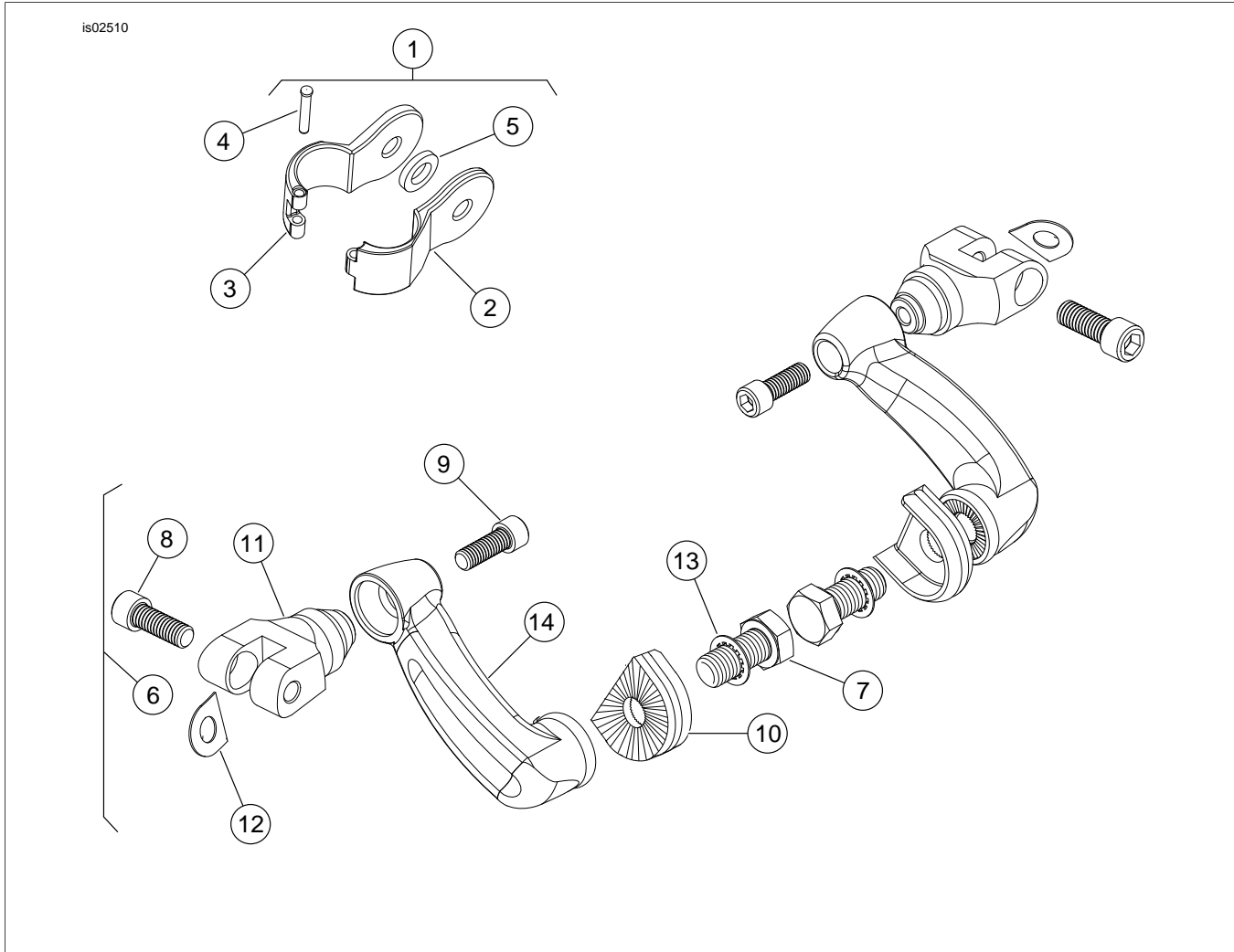

Figure 2. Service Parts: Adjustable Highway Footpeg Mounting Kits

Table 1. Service Parts Table

Item	Description (Quantity)	Part Number	Item	Description (Quantity)	Part Number
Kit Number 50929-03			Kit Number 50832-07		
1	Assembly, mounting clamp (2)	50928-03	1	Assembly, mounting clamp (2)	50831-07
2	• Clamp, mount (male) (2)	Not sold	2	• Clamp, mount (male) (2)	Not sold
3	• Clamp, mount (female) (2)	Not sold	3	• Clamp, mount (female) (2)	Not sold
4	• Pin, hinge (2)	Not sold	4	• Pin, hinge (2)	Not sold
5	• Flat washer, 9/16 inch (2)	6091	5	• Flat washer, 9/16 inch (2)	6091
6	Assembly, footpeg extension (2)	50930-03	6	Assembly, footpeg extension (2)	50930-03

Table 1. Service Parts Table

Item	Description (Quantity)	Part Number	Item	Description (Quantity)	Part Number
7	• Screw, hex 1/2 x 1-3/8 inch (2)	4062	7	• Screw, hex 1/2 x 1-3/8 inch (2)	4062
8	• Screw, 3/8 x 1 inch (2) x 1-3/8 inch (2)	4087	8	• Screw, 3/8 x 1 inch (2) x 1-3/8 inch (2)	4087
9	• Screw, 5/16 x 7/8 inch (2)	4064	9	• Screw, 5/16 x 7/8 inch (2)	4064
10	• Adapter, clamp (2)	Not sold	10	• Adapter, clamp (2)	Not sold
11	• Clevis, male mount, chrome (2)	Not sold	11	• Clevis, male mount, chrome (2)	Not sold
12	• D-washer, 3/8 inch (2)	50912-72	12	• D-washer, 3/8 inch (2)	50912-72
13	• Lockwasher, internal tooth (2)	7133	13	• Lockwasher, internal tooth (2)	7133
14	• Extension arm, footpeg (2)	Not sold	14	• Extension arm, footpeg (2)	Not sold