



INSTRUCTIONS

-J02837

REV. 2006-07-12

ANGLED HIGHWAY PEG MOUNTING KIT

GENERAL

Kit Number

50910-03A, 50924-03A, 50829-07, 50830-07

Models

These kits are designed for installation on Harley-Davidson models equipped with 1-1/4 inch diameter front engine guards. Kits 50910-03A and 50829-07 are angled long and kits 50924-03A and 50830-07 are angled short.

Additional Parts Required

This kit requires installing a set of male-mount style footpegs. A variety of footpegs are sold separately and available from any Harley-Davidson dealer.

NOTE

A Service Manual for your model motorcycle is available from any Harley-Davidson Dealer.

Kit Contents

See Figure 2 and Table 1.

INSTALLATION

WARNING

Position footpegs so rider can operate foot controls without interference. Failure to have full access to foot controls can cause loss of control, which could result in death or serious injury. (00313a)

WARNING

Mount the footpegs so they will not strike the ground during cornering. Footpegs striking the ground during cornering can cause loss of control, resulting in death or serious injury. (00458b)

1. Determine what height on the engine guard you prefer for the final mounting of the footpeg mounts. Mark location, if desired.
2. See Figure 2. Obtain the mounting clamp (11) from kit. Position the clamp halves around the engine guard at the desired height and install with hinge pin head facing upward. The "cogged" face of the clamp should face the extension arm.
3. Obtain the washer (5), screw (8) and one of the angled arms (11) (long or short depending on kit number) from kit. Using the screw, align and install the angled arm with washer (5) positioned between the clamp "ears".
4. See Figure 1. Position the angled arm such that footpeg will pivot upward and toward the rear of the motorcycle. Do not tighten completely at this time.

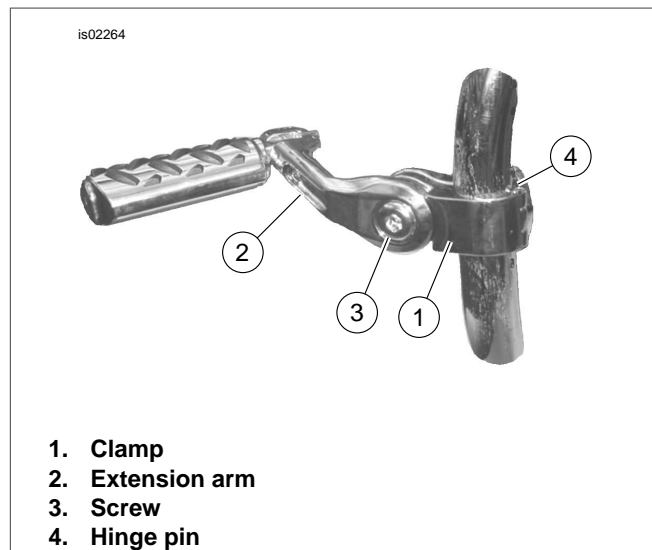

Figure 1. Engine Guard Footpeg Mounting (Shown Installed with Footpeg)

NOTE

The footpeg will be a tight fit if the D-spring washer is installed correctly.

5. Refer to Figure 1 and Figure 2. Obtain the footpeg (sold separately), D-spring washer (10) and screw (7) from kit. Install the D-spring washer so it is positioned inside the footpeg mount (arm) with the square "D" edge towards the inside of the mount. Hold the washer in place and slide the footpeg into position. Install the screw and tighten footpeg screw to 19 ft-lbs (26 Nm).
6. Note the two small tapped holes on the back side of the footpeg mount clevis area. Install the setscrew to the lower of the two holes. The angle of the footpeg is adjusted by running the set screw in and out. Repeat Steps 1 through 6 for the opposite side.
7. Position the footpeg assemblies so they are at equal heights and symmetrical. Securely tighten each assembly until it cannot be rotated on the engine guard with reasonable foot pressure but do not exceed 55-60 ft-lbs (75-81 Nm) on item 8.

WARNING

If footpeg mounting location increases motorcycle width, maintain clearance between motorcycle and surrounding persons or objects. Failure to maintain clearance could result in death or serious injury. (00314a)

SERVICE PARTS

is02265

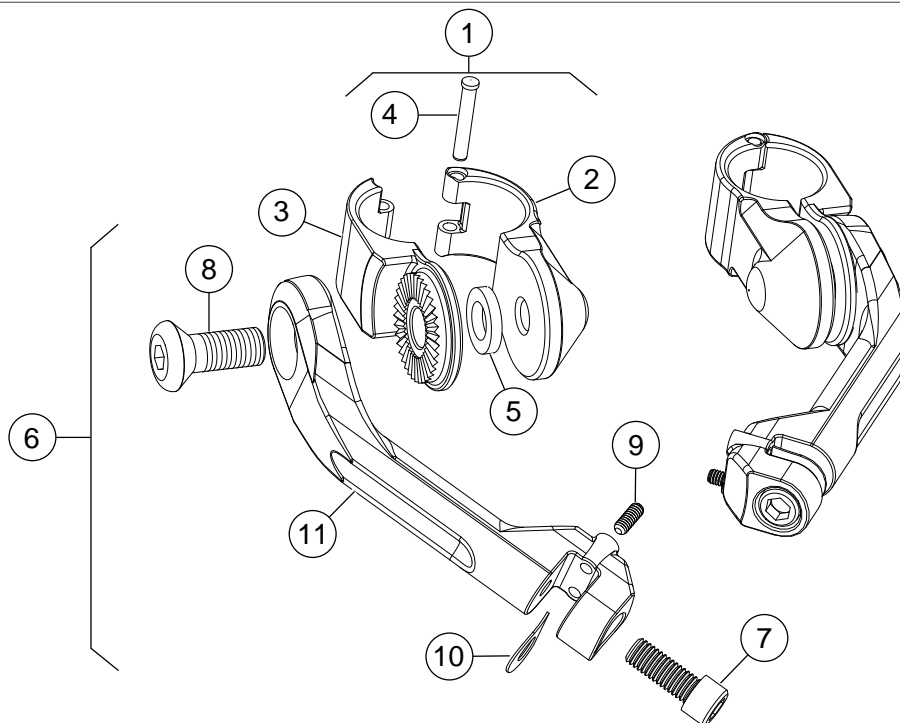

Figure 2. Service Parts: Engine Guard Footpeg Mounting Kit

Table 1. Service Parts Table

Item	Description (Quantity)	Part Number	Item	Description (Quantity)	Part Number
Kit number 50910-03A			Kit number 50924-03A		
1	Assembly, mounting clamp (2)	50931-03A	1	Assembly, mounting clamp (2)	50931-03A
2	• Clamp, mounting (female) (2)	Not sold separately	2	• Clamp, mounting (female) (2)	Not sold separately
3	• Clamp, mounting (male) (2)	Not sold separately	3	• Clamp, mounting (male) (2)	Not sold separately
4	• Pin, hinge (2)	Not sold separately	4	• Pin, hinge (2)	Not sold separately
5	• Washer, 9/16 inch (2)	6459	5	• Washer, 9/16 inch (2)	6459
6	Assembly, peg extension (long) (2)	50918-03	6	Assembly, peg extension (short) (2)	50927-03
7	• Screw, 3/8 x 1 inch (2)	4087	7	• Screw, 3/8 x 1 inch (2)	4087
8	• Screw, 1/2 x 1-1/4 inch (2)	Not sold separately	8	• Screw, 1/2 x 1-1/4 inch (2)	Not sold separately
9	• Set screw, 10-24 (2)	3338	9	• Set screw, 10-24 (2)	3338
10	• D-spring washer, 3/8 inch (2)	50912-72	10	• D-spring washer, 3/8 inch (2)	50912-72
11	• Arm, angled, long (2)	Not sold separately	11	• Arm, angled, long (2)	Not sold separately
Kit number 50829-07			Kit number 50830-07		
1	Assembly, mounting clamp (2)	50931-07	1	Assembly, mounting clamp (2)	50931-07
2	• Clamp, mounting (female) (2)	Not sold separately	2	• Clamp, mounting (female) (2)	Not sold separately
3	• Clamp, mounting (male) (2)	Not sold separately	3	• Clamp, mounting (male) (2)	Not sold separately
4	• Pin, hinge (2)	Not sold separately	4	• Pin, hinge (2)	Not sold separately
5	• Washer, 9/16 inch (2)	6459	5	• Washer, 9/16 inch (2)	6459
6	Assembly, peg extension (long) (2)	50918-03	6	Assembly, peg extension (short) (2)	50927-03

Table 1. Service Parts Table

Item	Description (Quantity)	Part Number	Item	Description (Quantity)	Part Number
7	• Screw, 3/8 x 1 inch (2)	4087	7	• Screw, 3/8 x 1 inch (2)	4087
8	• Screw, 1/2 x 1-1/4 inch (2)	Not sold separately	8	• Screw, 1/2 x 1-1/4 inch (2)	Not sold separately
9	• Set screw, 10-24 (2)	3338	9	• Set screw, 10-24 (2)	3338
10	• D-spring washer, 3/8 inch (2)	50912-72	10	• D-spring washer, 3/8 inch (2)	50912-72
11	• Arm, angled, long (2)	Not sold separately	11	• Arm, angled, long (2)	Not sold separately
NOTE: Long arm is shown in illustration. Assembly procedure is the same for Short arm.					