



INSTRUCTIONS

-J01395

REV. 2006-10-02

DETACHABLE PASSENGER Sissy BAR UPRIGHT KITS

GENERAL

Kit Number

52723-06, 52805-97B, 52933-97B, and 52935-04

Models

For model fitment information, please see the P&A Retail Catalog or the Parts and Accessories section of www.harley-davidson.com (English only).

Additional Parts Required

Front Docking Point Kit 53803-06 and bracket 53805-99 (included in this kit) must be installed before sissy bar upright can be mounted. The Front Docking Point Kit 53803-06 can be purchased separately from a Harley-Davidson dealer.

WARNING

The rider's safety depends upon the correct installation of this kit. If the procedure is not within your capabilities or you do not have the correct tools, have a Harley-Davidson dealer perform the installation. Improper installation of this kit could result in death or serious injury. (00308a)

Kit Contents

Table 1. Kit Contents

Description (Quantity)	Part Number
Detachable sissy bar upright	Not Sold Separately
Bracket (2)	53805-99

INSTALLATION

1. See Figure 1 and Figure 2. Properly position the front and rear docking points. Install bracket (1) on each side as shown.

NOTE

There is a slight bend in the bracket. The bracket will bend away from the motorcycle frame. The rear bracket hole is larger in diameter than the front bracket hole.

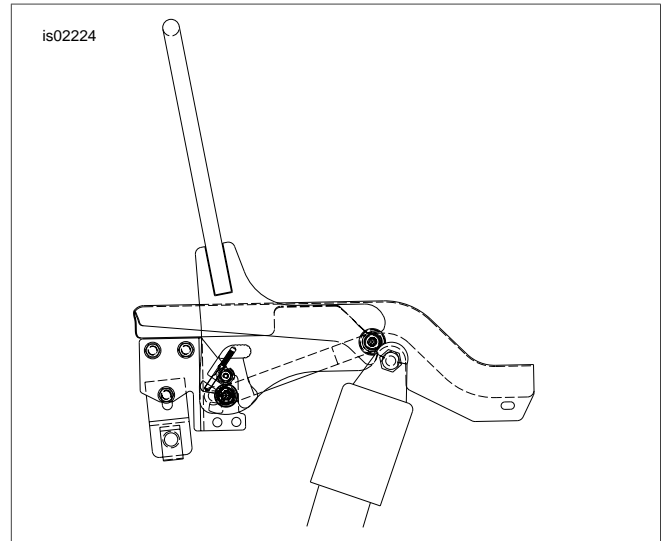
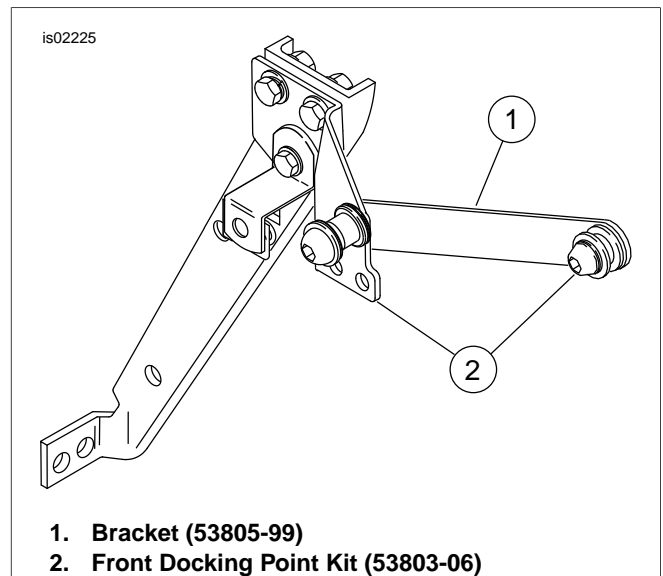

Figure 1. Detachable Sissy Bar Upright



1. Bracket (53805-99)
2. Front Docking Point Kit (53803-06)

Figure 2. Front Docking Point Kit and Bracket

2. See Figure 3. While standing behind the motorcycle, place the front backrest notches into the front docking points. Make sure the notches seat fully into the front docking points.

NOTE

See Figure 4. For 1997 and later FL models, front docking points should be rotated to touch the back side of the rear shock.

NOTE

Rear docking points may be damaged if rotary latches and side plates are not properly aligned. If the latch does not easily close, do not force. Check alignment as described in Step 3.

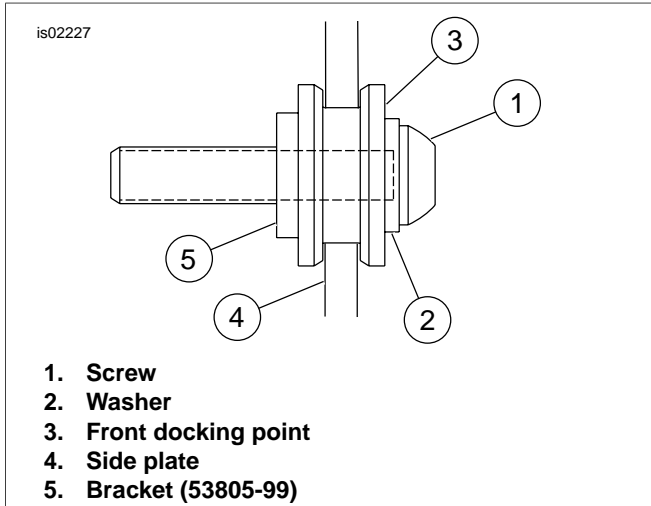

Figure 3. Side Plate and Front Docking Point Fully Engaged

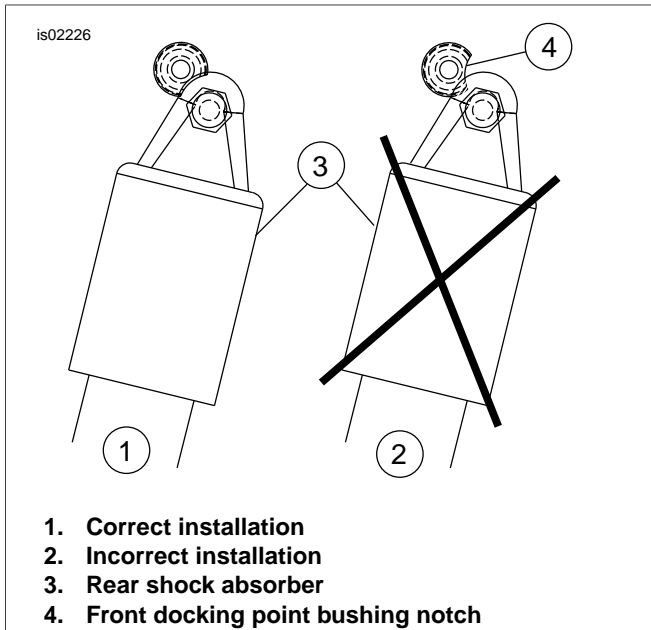

Figure 4. Position of Front Docking Point Notch

3. See Figure 5 and Figure 6. Position the latches over the rear docking points. Check to be sure the latches fit into the neck of the rear docking points as shown. This may require some gentle squeezing or spreading of the side plates.
4. Push the rear of the side plates downward and close the latches by pressing the latch lever as far forward as it will go. You will hear a **CLICK** when the latch is in place. **If the latch does not easily close, do not force.** Recheck alignment as described in Step 3.

NOTE

The front and rear docking points must be fully engaged. See Figures 3 through 6 for correct engagement. If docking points

are not fully engaged it could shift position or come loose during operation.

WARNING

After installing backrest, pull upward to be sure it is locked in position. While riding, a loose backrest can shift causing loss of control, which could result in death or serious injury. (00386a)

5. See Figure 5. To remove side plates, press the release button on each side and pull the latch levers back. Carefully lift the rear of the side plates up and pull the side plates out of the front docking points.

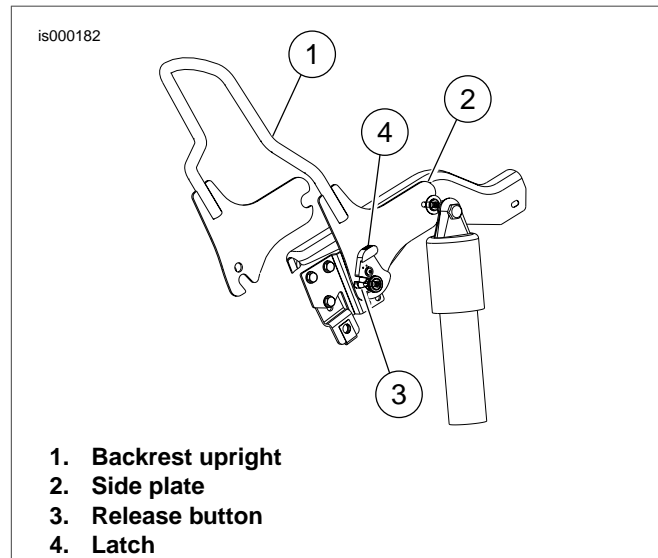

Figure 5. Installed Backrest and Hardware

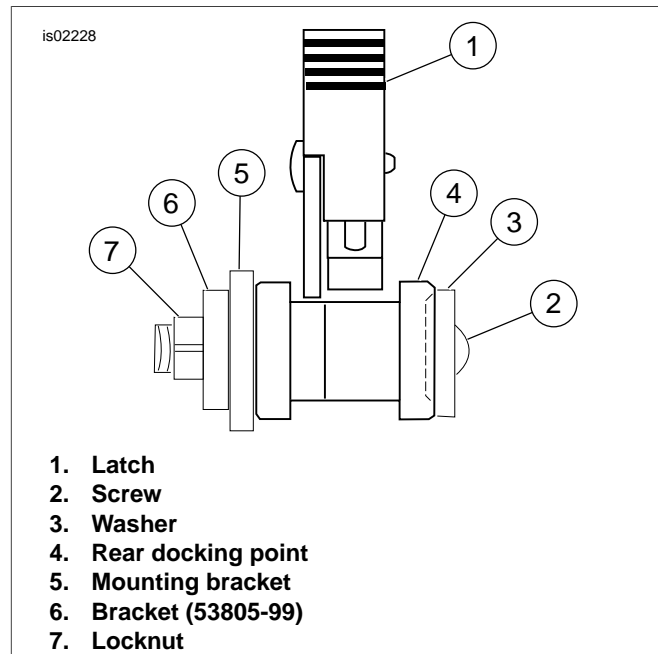

Figure 6. Rear Docking Point Latch Alignment