



INSTRUCTIONS

-J01320

REV. 2-28-02

Kit Number 77183-02

CRUISE CONTROL KIT FOR FLHR/I MODELS

General

This cruise control kit is designed for installation on 2002 and later FLHR/I (Road King) Model Motorcycles.

See *Service Parts* for kit contents.

WARNING

The rider's safety depends on the correct installation of this kit. If the following installation procedures are not within your capabilities, or if you do not have the correct tools, have your Harley-Davidson dealer perform this installation. Failure to do the installation correctly could result in death or serious injury.

Service Manual Required

This Instruction Sheet refers the installer to the appropriate FLT Service Manual for many procedures. Therefore, Harley-Davidson recommends that you do not attempt to install this kit without having a copy of the FLT Service Manual applicable to your vehicle.

NOTE

A *Service Manual* for your vehicle is available from your Harley-Davidson dealer.

Installation

1. Remove seat, left saddlebag, left side cover and air cleaner assembly following instructions in applicable Service Manual.
2. Review the "CRUISE CONTROL-Ultra MODELS" section in the applicable FLT Service Manual before attempting to install this kit.

Install Cruise Control Module

WARNING

To protect against shock and accidental start-up of vehicle, disconnect the negative battery cable before proceeding. Inadequate safety precautions could result in death or serious injury.

WARNING

Always disconnect the negative battery cable first. If the positive cable should contact ground with the negative cable installed, the resulting sparks may cause a battery explosion which could result in death or serious injury.

3. Remove battery.
4. See Figure 1. In battery box, identify the location of the three mounting holes (on left side of panel) for mounting the cruise control module.
5. See Service Parts Illustration. Obtain the Cruise Control Module (1) with cruise cable attached and three Grommets (5) from kit. Install the grommets on studs of cruise control module, with small diameters outward.

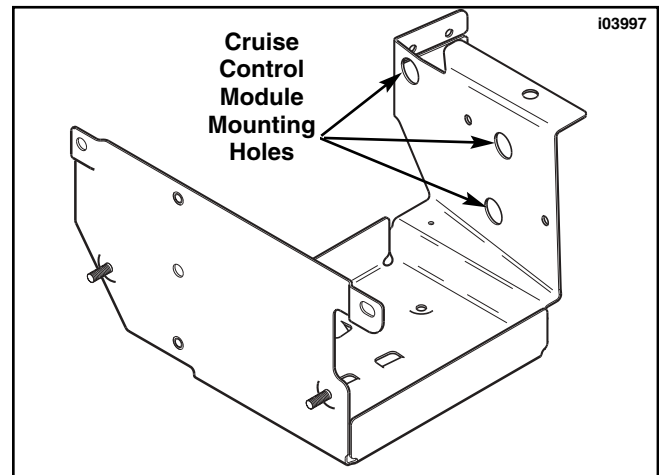

Figure 1. Battery Box (Right Side View)

6. See Figure 2. While holding cruise control module in place near its mounting location, feed the cruise control cable through the hole in frame crossmember plate and route under rear spark plug wire staying on inner side of fuel line components. Carefully curve cable toward the right and continue routing up under the fuel tank and over the top of the engine stabilizer bracket, then down between cylinder heads. Leave in place temporarily. See Service Parts Illustration and obtain a harness retainer (4) from kit and secure the cruise cable to crossmember plate with barb as shown. On California models, remove the EVAP hose from cable clip and secure hose with one of the cable ties (6).

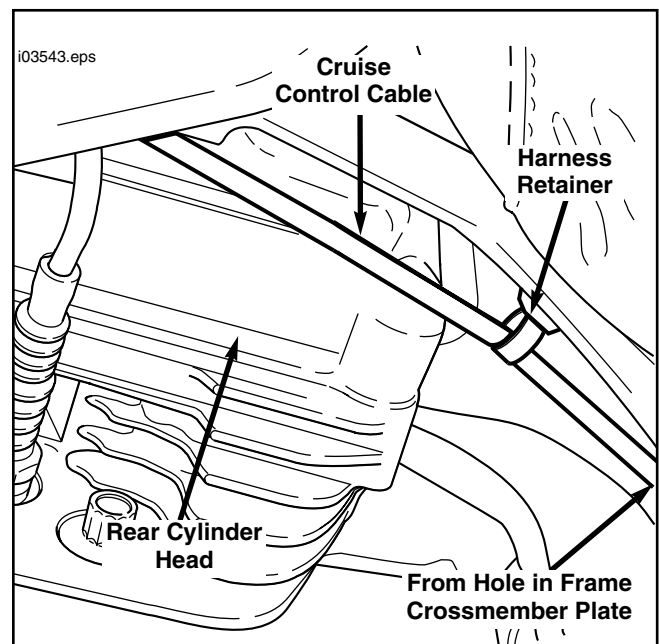

Figure 2. Routing Cruise Cable from Cruise Control Module to Carburetor or Induction Module (Left Side View)

NOTE

Prior to performing the next step, it may be necessary to cut the wire ties securing the main harness to the frame tube (above mounting area) and temporarily move harness aside to allow adequate room for cruise module installation. It may also be necessary to move the charcoal canister hose to the side and secure to frame tube with cable tie (8).

- See Figure 3. Remove the fuse block cover panel by pulling straight out from mounts and temporarily position the cover away from the mounting area. Align the cruise module studs (and grommets) with mounting holes in battery box and push module firmly into position. Make sure grommets enter mounting holes in battery box.
- See Service Parts Illustration. Obtain the three flange locknuts (7) and install to cruise control module studs (inside battery box). Tighten nuts 9-11 ft-lbs (12.2-15 Nm). Locate the 10-place connector harness (normally wire tied to frame tube next to battery box) and cut the tie. Route downward and install the 10-place connector into cruise module.

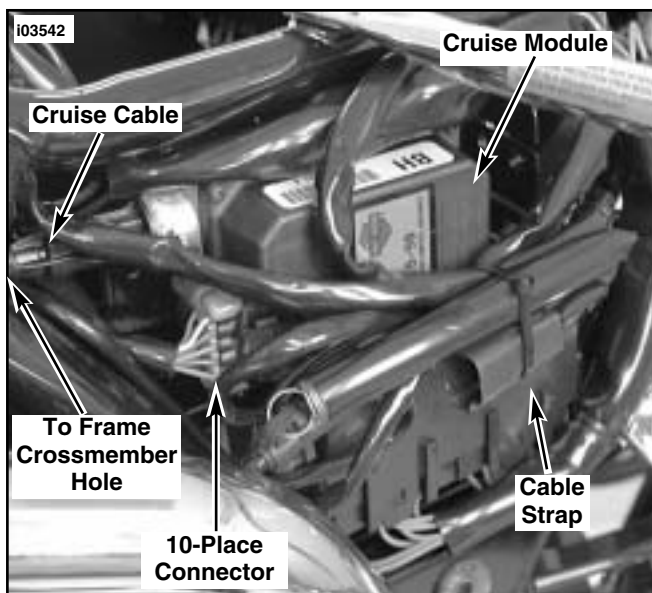

Figure 3. Mount Cruise Control Module

- Reinstall the fuse block cover panel by sliding (side channels) back onto mounts. See Service Parts Illustration. Obtain cable tie/s (8) from kit. Bundle wire harnesses (moved to install cruise module) along side of cruise module to allow the side cover to be reinstalled.
- Return to cruise cable end near carburetor or induction module. Follow instructions in applicable Service Manual to connect cruise cable to carburetor or induction module. **NOTE:** See Service Parts Illustration. Use new retaining ring (6) from kit when installing cable end to carburetor/Induction module.

Install New Right Handlebar Control with Harness

CAUTION

Do not remove the switch housing assembly without first placing a 5/32 inch cardboard insert between the brake lever and lever bracket. Removal without the insert may result in damage to the rubber boot and plunger of the Front Stoplight Switch.

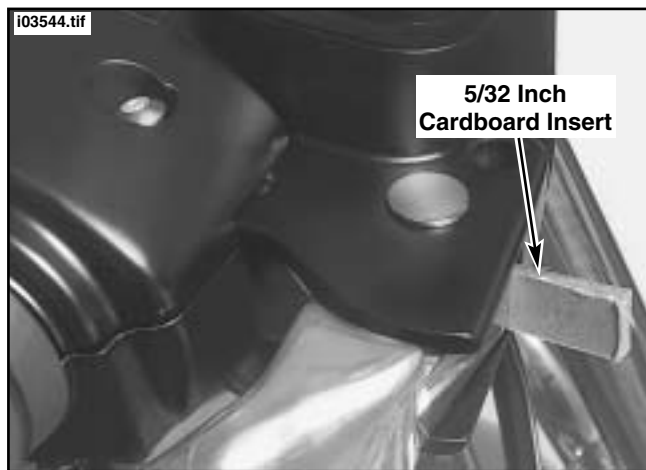

Figure 4. Install Cardboard Insert

NOTE

Use the eyelet of an ordinary cable strap if the cardboard insert is not available.

- See Figure 4. Place a 5/32 inch cardboard insert between the brake lever and lever bracket.
- Using a T27 TORX drive head, remove two screws with flat washers securing the handlebar clamp to the master cylinder housing. Remove brake lever/master cylinder assembly and clamp from the handlebar. Use a cable tie or other means to keep the assembly out of the way.
- Using T25 TORX drive head, remove the upper and lower switch housing screws.
- Remove the friction shoe from the end of the tension adjuster screw. Save friction shoe for reinstallation.

NOTE

The friction shoe is a loose fit and may fall out or become dislodged if the lower switch housing is turned upside down or shaken.

- See Figure 5. Remove the brass ferrules from the notches on the inboard side of the throttle control grip, then remove ferrules from the cable end fittings. Save ferrules for reinstallation.

NOTE

It is not necessary to remove the throttle control grip.

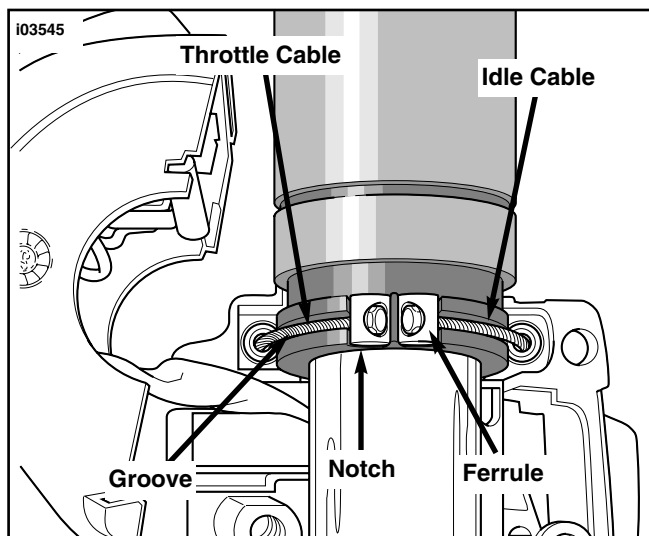

Figure 5. Remove Throttle and Idle Control Cables

16. See Figure 6. Pull the crimped inserts at the end of the throttle and idle control cable housings from the lower switch housing. For best results, use a rocking motion while pulling. Place a drop of light oil on the retaining rings, if necessary. Save inserts for re-installation.

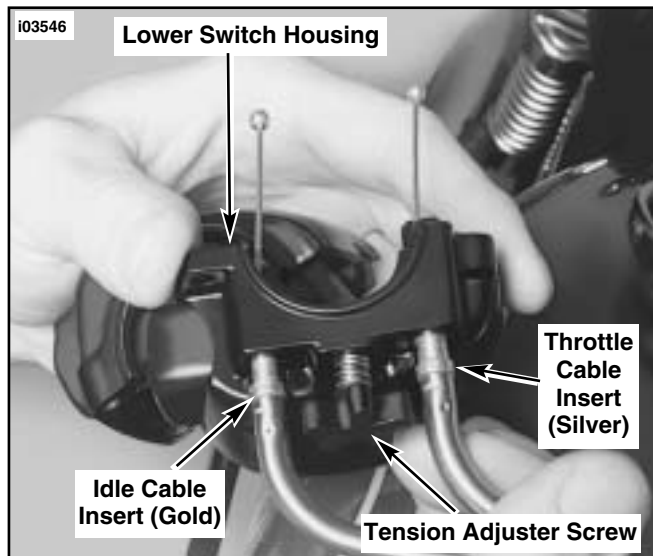

Figure 6. Upper Right Handlebar Switch Housing

17. Remove the cables from the switch housing, then separate the upper and lower switch halves.
18. Follow the instructions in applicable Service Manual and remove windshield and nacelle.

NOTE

When performing the next Step, the right side Deutsch Electrical Connectors are Black; the left side Deutsch Electrical Connectors are Grey.

19. Trace the right handlebar wiring harness to the 6-place Deutsch connector and disconnect connector halves. Note the existing harness routing and cable ties securing harness to handlebars. Remove and discard the right hand control and harness assembly.
20. See Service Parts Illustration. Obtain the new Right Handlebar Control and Harness Assembly (2) from kit. Install the new harness 6-place connector in same place as connector removed in Step 19. Locate the unused 4-place connector half (next to the 6-place) and install the 4-Place connector from the new harness to the 4-place connector in headlamp assembly.
21. At new handlebar control assembly, hold the lower switch housing with concave side facing upward. Install the tension adjuster screw and spring with the friction shoe (saved from Step 14) so that pin hole is over the point of the Tension adjuster screw. Adjust the tension adjuster two or three turns to hold assembly in place.

NOTE

The friction shoe is a loose fit and may fall out or become dislodged if the switch housing is turned upside down or shaken.

22. Refer to Figure 6. Push the throttle and idle control cables into the lower switch housing until they snap into place. Perform the following:
- Obtain the crimped inserts removed in Step 16. Note the different diameter inserts crimped into the end of the throttle and idle control cable housings.
 - Push the larger diameter insert (silver) on the throttle cable housing into the larger hole in front of the tension adjuster screw.
 - Push the smaller diameter insert (gold) on the idle cable housing into the smaller hole at the rear of the tension adjuster screw.

NOTE

To aid assembly, place a drop of light oil on the retaining rings of the crimped inserts. Always replace the retaining rings if damaged or distorted.

23. Slide the throttle control grip towards motorcycle until it bottoms against the closed end of the handlebar. Rotate the grip so that the ferrule notches are at the top. To prevent binding, pull the grip back about 1/8 inch (3.2 mm).
24. Refer to Figure 5. Position the new lower switch housing beneath the throttle control grip. Install the brass ferrules onto the cables so that the end fittings seat in the ferrule recess. Seat the ferrules in their respective notches on the throttle control grip. Verify that the cables are captured in the grooves molded into the grip.
25. Position the upper switch housing over the handlebar and lower switch housing.
26. Verify that wire harness conduit runs in the depression at the bottom of the handlebar. Be sure that the upper switch housing harness will not be pinched under the handlebar when the switch housing screws are tightened.
27. Start the upper and lower switch housing screws, but do not tighten.

CAUTION

Refer to Figure 4. Do not remove the 5/32 inch cardboard insert wedged between the brake lever and lever bracket. Removal will result in damage to the rubber boot and plunger of the Front Stoplight Switch during installation of the master cylinder assembly.

28. See Figure 7. Position the brake lever/master cylinder assembly inboard of the switch housing assembly engaging the tab on the lower switch housing in the groove at the top of the brake lever bracket.
29. Align the holes in the handlebar clamp with those in the master cylinder housing and start the two screws (with flat washers). Position the assembly for rider comfort. Beginning with the top screw, tighten the screws to 60-80 in-lbs (6-9 Nm) using a T27 TORX drive head.

NOTE

When performing the following Step, tighten the lower switch housing screw first so that any gap between the upper and lower housings is at the front of the switch.

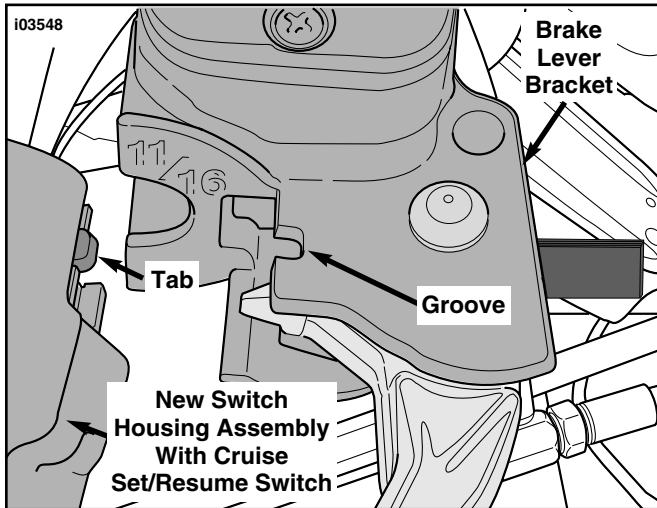

Figure 7. Installing Brake Lever/Master Cylinder Assembly to Right Switch Housing Assemblies

30. Using a T25 TORX drive head, tighten the lower then upper switch housing screws to 35-45 **in-lbs** (4-5 Nm).
31. Remove the cardboard insert between the brake lever and lever bracket.
32. See Service Parts Illustration. Obtain two harness retainers (4) from kit. Adjust the harness so it runs under the handlebar and secure harness conduit to holes in lower side of handlebar by inserting barbed ends of retainers.

Install New Left Handlebar Control with Harness

NOTE

Prior to performing the next step, cut all cable ties securing left control switch harness to handlebars and discard.

33. Trace the left control switch harness wiring to the headlamp area (with nacelle removed) and locate the Grey 6-place Deutsch Connector. Disconnect the handlebar switch half from the connector.
34. Using a T27 TORX drive head, remove the two screws with flat washers securing the handlebar clamp to the clutch lever bracket. Remove the clutch hand lever assembly and clamp from the handlebar. Save all hardware for reinstallation.
35. Using a T25 TORX drive head, remove the upper and lower switch housing screws. Save switch housing screws for reinstallation. Remove the left handlebar control and harness and discard.

NOTE

It is not necessary to remove the left handlebar grip. Leave grip in place.

36. See Service Parts Illustration. Obtain the new Left Handlebar Control with Harness (3) from kit.
37. See Figure 8. Position the left switch control upper and lower housings onto the handlebar. Be sure that rib on outboard side of switch housings fits in groove molded into the grip.

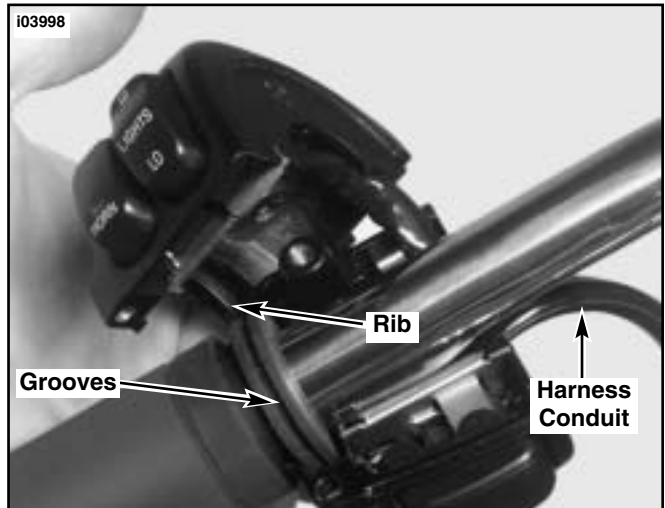

Figure 8. Installing Left Handlebar Switch Housing

38. Verify that the wire harness conduit runs in the groove at the bottom of the handlebar. Be sure that the upper switch housing harness will not be pinched under the handlebar when the switch housing screws are tightened.
39. Start the upper and lower switch housing screws saved in Step 35, but do not completely tighten at this time.
40. See Figure 9. Position the clutch hand lever assembly inboard of the switch housing assembly engaging the tab on the lower switch housing in the groove at the bottom of the clutch lever bracket. Be sure that harness will not be pinched when installing handlebar clamp. Harness should reside in recess between handlebar clamp and clutch lever bracket.
41. Align the holes in the handlebar clamp with those in the clutch lever bracket and start the two screws (with flat washers) saved from Step 34. Position the assembly for rider comfort. Beginning with the top screw, tighten the screws to 60-80 **in-lbs** (7-9 Nm) using a T27 TORX drive head.

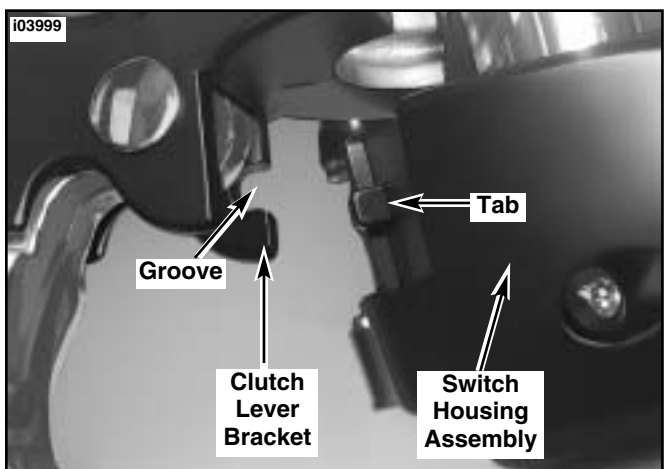

Figure 9. Positioning Clutch Lever Bracket with Left Handlebar Switch Housings

42. Using a T25 TORX drive head, tighten the lower and upper switch housing screws to 35-45 **in-lbs** (4-5 Nm).

NOTE

Always tighten the lower switch housing screw first so that any gap between the upper and lower housings is at the front of the switch.

43. Route left hand control harness under handlebar and down to headlamp area (with nacelle removed). Locate the 6-place Deutsch Connector and connect the 6-place control harness connector.
44. Locate the unused 4-place Deutsch Connector and connect the 4-place control harness connector.
45. See Service Parts Illustration. Obtain two wire harness retainers (4) from kit and secure harness to handlebar in two places by installing barbs on retainers into holes in handlebar.
46. Follow instructions in applicable Service Manual and install fairing nacelle and windshield.
47. Follow instructions in Service Manual and install left saddlebag, left side cover and air cleaner assembly.

WARNING

Always connect the positive battery cable first. If the positive cable should contact ground with the negative cable installed, the resulting sparks may cause a battery explosion which could result in death or serious injury.

48. Reconnect battery, positive cable first.

49. Install seat.

WARNING

After installing seat, pull upward on front of seat to be sure it is locked in position. If seat is loose, it could shift position during vehicle operation and startle the rider, causing loss of control and death or serious injury.

CRUISE CABLE ADJUSTMENT AND FINAL TEST

50. Perform cruise cable adjustment. See "Cable Lash Initialization" in applicable Service Manual.
51. Refer to cruise control section in Owner's Manual for cruise control operating instructions.
52. Test ride motorcycle and verify cruise control is operating properly.



Service Parts

Part No. 77183-02

Date 2/02

FLHR/I Cruise Control Kit

i04100

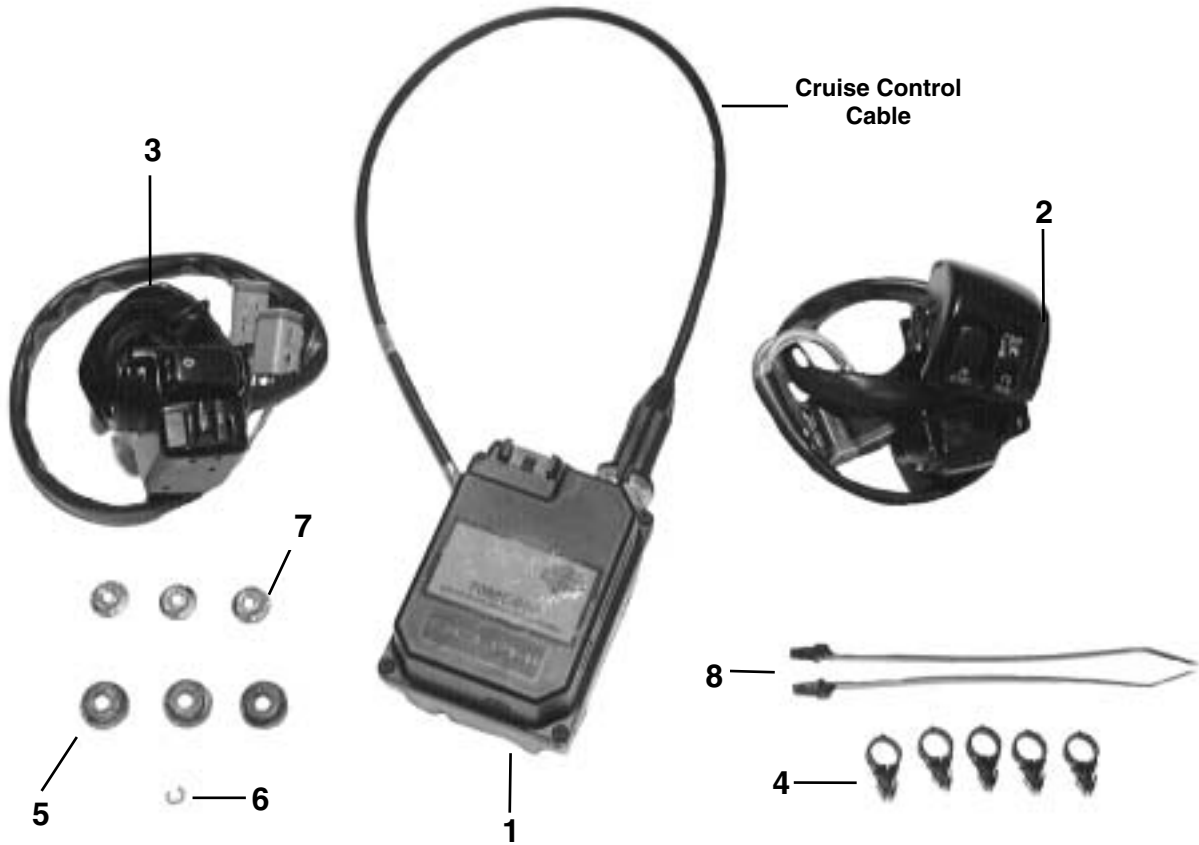

Item	Description/Qty	Part Number
1	Assembly cruise control w/harness	70955-98B
2	Assembly, hand control (right)	70419-02
3	Assembly, hand control (left)	70434-02
4	Retainer, wire harness (5)	70345-84
5	Grommet (3)	11497
6	Ring, retaining	11193
7	Nut, flange locking (3)	7499
8	Ties, cable (2)	10065